

6-135. The two-bar mechanism consists of a lever arm AB and smooth link CD , which has a fixed collar at its end C and a roller at the other end D . Determine the force \mathbf{P} needed to hold the lever in the position θ . The spring has a stiffness k and unstretched length $2L$. The roller contacts either the top or bottom portion of the horizontal guide.

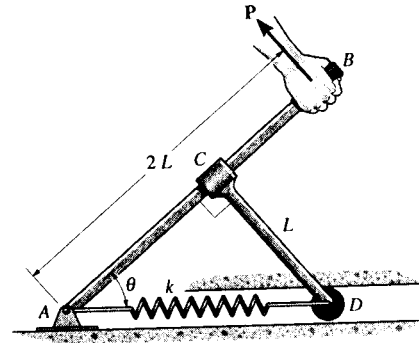

Free Body Diagram : The spring compresses $x = 2L - \frac{L}{\sin \theta}$. Then, the spring force developed is $F_{sp} = kx = kL\left(2 - \frac{1}{\sin \theta}\right)$.

Equations of Equilibrium : From FBD (a),

$$\rightarrow \Sigma F_x = 0; \quad kL\left(2 - \frac{1}{\sin \theta}\right) - F_{CD} \sin \theta = 0$$

$$F_{CD} = \frac{kL}{\sin \theta} \left(2 - \frac{1}{\sin \theta}\right)$$

$$+\Sigma M_D = 0; \quad M_C = 0$$

From FBD (b),

$$+\Sigma M_A = 0; \quad P(2L) - \frac{kL}{\sin \theta} \left(2 - \frac{1}{\sin \theta}\right) (L \cot \theta) = 0$$

$$P = \frac{kL}{2 \tan \theta \sin \theta} (2 - \csc \theta) \quad \text{Ans}$$

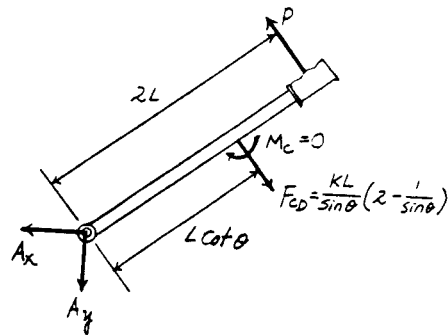
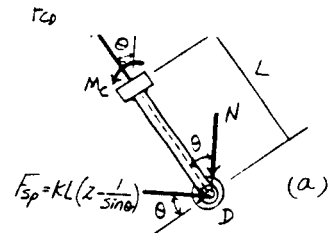

*6-136. Determine the force in each member of the truss and state if the members are in tension or compression.

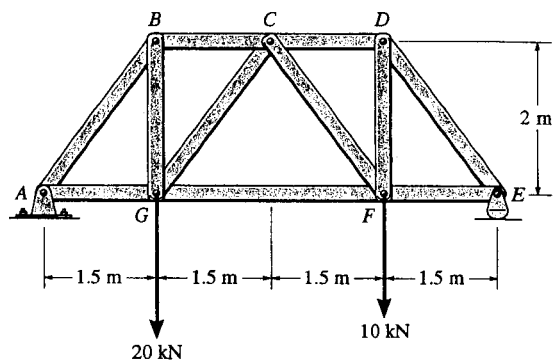

$$\curvearrow + \Sigma M_A = 0; \quad -20(1.5) - 10(4.5) + E_y(6) = 0$$

$$E_y = 12.5 \text{ kN}$$

$$\rightarrow \Sigma F_x = 0; \quad A_x = 0$$

$$+ \uparrow \Sigma F_y = 0; \quad A_y - 20 - 10 + 12.5 = 0$$

$$A_y = 17.5 \text{ kN}$$

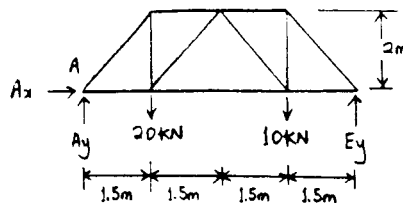

Joint A :

$$+ \uparrow \Sigma F_y = 0; \quad 17.5 - \frac{4}{5}F_{AB} = 0$$

$$F_{AB} = 21.88 = 21.9 \text{ kN (C)} \quad \text{Ans}$$

$$\rightarrow \Sigma F_x = 0; \quad F_{AG} - \frac{3}{5}(21.88) = 0$$

$$F_{AG} = 13.125 = 13.1 \text{ kN (T)} \quad \text{Ans}$$

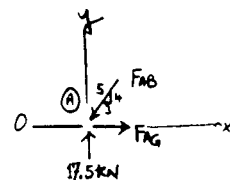

Joint B :

$$\rightarrow \Sigma F_x = 0; \quad -F_{BC} + \frac{3}{5}(21.88) = 0$$

$$F_{BC} = 13.1 \text{ kN (C)} \quad \text{Ans}$$

$$+ \uparrow \Sigma F_y = 0; \quad \frac{4}{5}(21.88) - F_{BG} = 0$$

$$F_{BG} = 17.5 \text{ kN (T)} \quad \text{Ans}$$

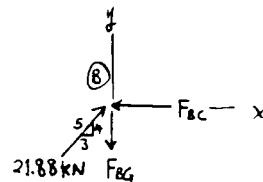

6-136 cont'd

Joint G:

$$+\uparrow \Sigma F_y = 0; \quad 17.5 - 20 + \frac{4}{5} F_{GC} = 0$$

$$F_{GC} = 3.125 = 3.12 \text{ kN (T)} \quad \text{Ans}$$

$$\rightarrow \Sigma F_x = 0; \quad \frac{3}{5}(3.125) + F_{GF} - 13.125 = 0$$

$$F_{GF} = 11.2 \text{ kN (T)} \quad \text{Ans}$$

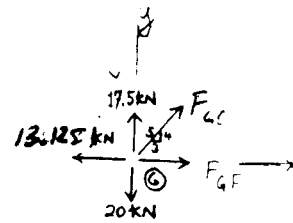

Joint C:

$$+\uparrow \Sigma F_y = 0; \quad \frac{4}{5} F_{CF} - \frac{4}{5}(3.125) = 0$$

$$F_{CF} = 3.12 \text{ kN (C)} \quad \text{Ans}$$

$$\rightarrow \Sigma F_x = 0; \quad 13.12 - \frac{3}{5}(3.125) - \frac{3}{5}(3.125) - F_{CD} = 0$$

$$F_{CD} = 9.375 = 9.38 \text{ kN (C)} \quad \text{Ans}$$

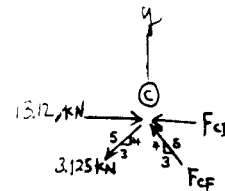

Joint D:

$$\rightarrow \Sigma F_x = 0; \quad 9.375 - \frac{3}{5}(F_{DE}) = 0$$

$$F_{DE} = 15.63 = 15.6 \text{ kN (C)} \quad \text{Ans}$$

$$+\uparrow \Sigma F_y = 0; \quad \frac{4}{5}(15.63) - F_{DF} = 0$$

$$F_{DF} = 12.5 \text{ kN (T)} \quad \text{Ans}$$

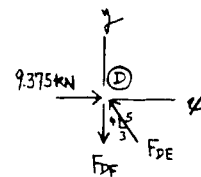

Joint F:

$$\rightarrow \Sigma F_x = 0; \quad \frac{3}{5}(3.125) - 11.25 + F_{EF} = 0$$

$$F_{EF} = 9.38 \text{ kN (T)} \quad \text{Ans}$$

$$+\uparrow \Sigma F_y = 0; \quad 12.5 - 10 - \frac{4}{5}(3.125) = 0 \quad \text{Check!}$$

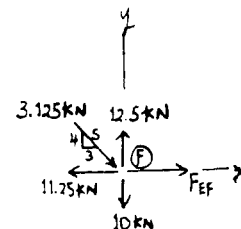

6-137. Determine the force in members AB , AD , and AC of the space truss and state if the members are in tension or compression.

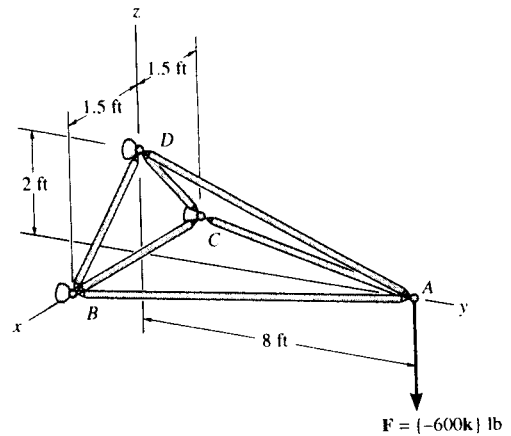

Method of Joints: In this case the support reactions are not required for determining the member forces.

Joint A

$$\Sigma F_z = 0; \quad F_{AD} \left(\frac{2}{\sqrt{68}} \right) - 600 = 0$$

$$F_{AD} = 2473.86 \text{ lb (T)} = 2.47 \text{ kip (T)} \quad \text{Ans}$$

$$\Sigma F_x = 0; \quad F_{AC} \left(\frac{1.5}{\sqrt{66.25}} \right) - F_{AB} \left(\frac{1.5}{\sqrt{66.25}} \right) = 0$$

$$F_{AC} = F_{AB} \quad [1]$$

$$\Sigma F_y = 0; \quad F_{AC} \left(\frac{8}{\sqrt{66.25}} \right) + F_{AB} \left(\frac{8}{\sqrt{66.25}} \right) - 2473.86 \left(\frac{8}{\sqrt{68}} \right) = 0$$

$$0.9829 F_{AC} + 0.9829 F_{AB} = 2400 \quad [2]$$

Solving Eqs. [1] and [2] yields

$$F_{AC} = F_{AB} = 1220.91 \text{ lb (C)} = 1.22 \text{ kip (C)} \quad \text{Ans}$$

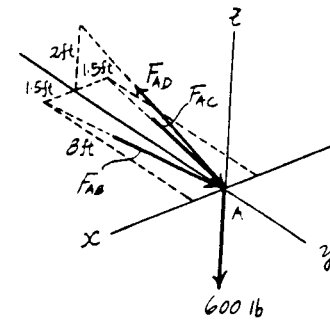

7-1. The column is fixed to the floor and is subjected to the loads shown. Determine the internal normal force, shear force, and moment at points A and B.

Free body Diagram : The support reaction need not be computed in this case.

Internal Forces : Applying equations of equilibrium to the top segment sectioned through point A, we have

$$\rightarrow \Sigma F_x = 0; \quad V_A = 0 \quad \text{Ans}$$

$$+ \uparrow \Sigma F_y = 0; \quad N_A - 6 - 6 = 0 \quad N_A = 12.0 \text{ kN} \quad \text{Ans}$$

$$\curvearrowleft + \Sigma M_A = 0; \quad 6(0.15) - 6(0.15) - M_A = 0 \quad M_A = 0 \quad \text{Ans}$$

Applying equations of equilibrium to the top segment sectioned through point B, we have

$$\rightarrow \Sigma F_x = 0; \quad V_B = 0 \quad \text{Ans}$$

$$+ \uparrow \Sigma F_y = 0; \quad N_B - 6 - 6 - 8 = 0 \quad N_B = 20.0 \text{ kN} \quad \text{Ans}$$

$$+ \Sigma M_B = 0; \quad 6(0.15) - 6(0.15) - 8(0.15) + M_B = 0 \\ M_B = 1.20 \text{ kN} \cdot \text{m} \quad \text{Ans}$$

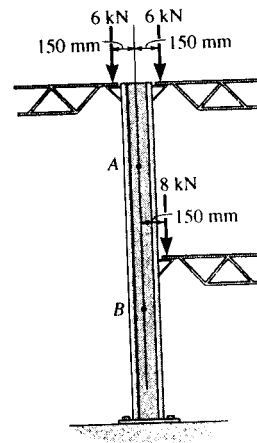
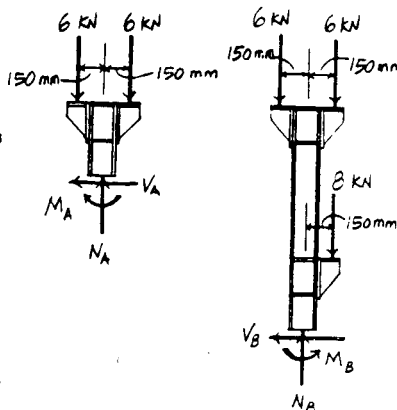

7-2. The rod is subjected to the forces shown. Determine the internal normal force at points A, B, and C.

Free body Diagram : The support reaction need not be computed in this case.

Internal Forces : Applying equations of equilibrium to the top segment sectioned through point A, we have

$$+ \uparrow \Sigma F_y = 0; \quad N_A - 550 = 0 \quad N_A = 550 \text{ lb} \quad \text{Ans}$$

Applying equations of equilibrium to the top segment sectioned through point B, we have

$$+ \uparrow \Sigma F_y = 0; \quad N_B - 550 + 150 + 150 = 0 \\ N_B = 250 \text{ lb} \quad \text{Ans}$$

Applying equations of equilibrium to the top segment sectioned through point C, we have

$$+ \uparrow \Sigma F_y = 0; \quad N_C - 550 + 150 + 150 - 350 - 350 = 0 \\ N_C = 950 \text{ lb} \quad \text{Ans}$$

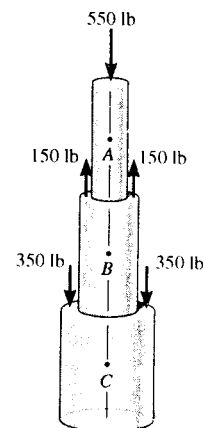
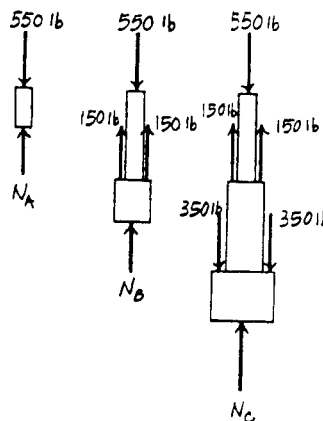

7-3. The forces act on the shaft shown. Determine the internal normal force at points A, B, and C.

Internal Forces : Applying the equation of equilibrium to the left segment sectioned through point A, we have

$$\rightarrow \Sigma F_x = 0; \quad N_A - 5 = 0 \quad N_A = 5.00 \text{ kN} \quad \text{Ans}$$

Applying the equation of equilibrium to the right segment sectioned through point B, we have

$$\rightarrow \Sigma F_x = 0; \quad 4 - N_C = 0 \quad N_C = 4.00 \text{ kN} \quad \text{Ans}$$

Applying the equation of equilibrium to the right segment sectioned through point C, we have

$$\rightarrow \Sigma F_x = 0; \quad N_B + 4 - 7 = 0 \quad N_B = 3.00 \text{ kN} \quad \text{Ans}$$

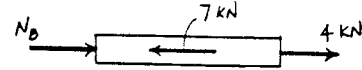
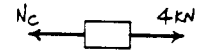
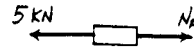
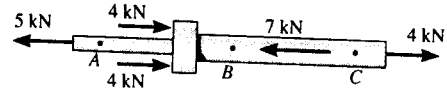

*7-4. The shaft is supported by the two smooth bearings A and B. The four pulleys attached to the shaft are used to transmit power to adjacent machinery. If the torques applied to the pulleys are as shown, determine the internal torques at points C, D, and E.

Internal Forces : Applying the equation of equilibrium to the left segment sectioned through point C, we have

$$\Sigma M_x = 0; \quad 40 - T_C = 0 \quad T_C = 40.0 \text{ lb} \cdot \text{ft} \quad \text{Ans}$$

Applying the equation of equilibrium to the left segment sectioned through point D, we have

$$\Sigma M_x = 0; \quad 40 + 15 - T_D = 0 \quad T_D = 55.0 \text{ lb} \cdot \text{ft} \quad \text{Ans}$$

Applying the equation of equilibrium to the right segment sectioned through point E, we have

$$\Sigma M_x = 0; \quad 10 - T_E = 0 \quad T_E = 10.0 \text{ lb} \cdot \text{ft} \quad \text{Ans}$$

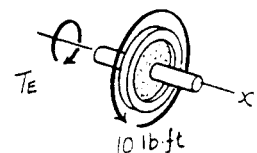
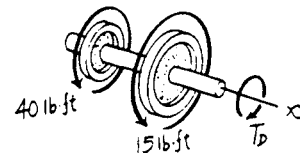
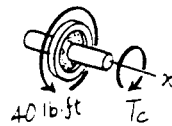
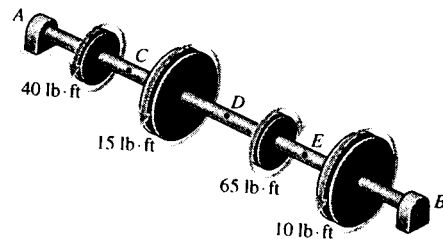

7-5. The shaft is supported by a journal bearing at A and a thrust bearing at B . Determine the normal force, shear force, and moment at a section passing through (a) point C , which is just to the right of the bearing at A , and (b) point D , which is just to the left of the 3000-lb force.

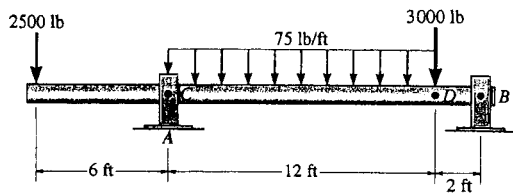

Prob. 7-5

$$\curvearrowleft + \Sigma M_B = 0; \quad -A_y(14) + 2500(20) + 900(8) + 3000(2) = 0$$

$$A_y = 4514 \text{ lb}$$

$$\rightarrow \Sigma F_x = 0; \quad B_x = 0$$

$$+ \uparrow \Sigma F_y = 0; \quad 4514 - 2500 - 900 - 3000 + B_y = 0$$

$$B_y = 1886 \text{ lb}$$

$$\curvearrowleft + \Sigma M_C = 0; \quad 2500(6) + M_C = 0$$

$$M_C = -15000 \text{ lb}\cdot\text{ft} = -15.0 \text{ kip}\cdot\text{ft}$$

$$\rightarrow \Sigma F_x = 0; \quad N_C = 0$$

$$+ \uparrow \Sigma F_y = 0; \quad -2500 + 4514 - V_C = 0$$

$$V_C = 2014 \text{ lb} = 2.01 \text{ kip}$$

$$\curvearrowleft + \Sigma M_D = 0; \quad -M_D + 1886(2) = 0$$

$$M_D = 3771 \text{ lb}\cdot\text{ft} = 3.77 \text{ kip}\cdot\text{ft}$$

$$\rightarrow \Sigma F_x = 0; \quad N_D = 0$$

$$+ \uparrow \Sigma F_y = 0; \quad V_D - 3000 + 1886 = 0$$

$$V_D = 1114 \text{ lb} = 1.11 \text{ kip}$$

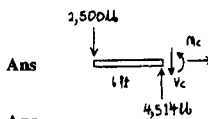
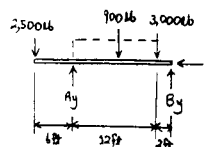

Ans

Ans

Ans

Ans

Ans

Ans

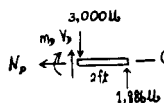

Ans

Ans

Ans

7-6. Determine the internal normal force and shear force, and the bending moment in the beam at points C and D. Assume the support at B is a roller. Point C is located just to the right of the 8-kip load.

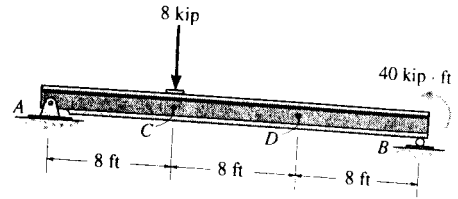

Support Reactions : FBD (a).

$$\begin{aligned} \left(+ \Sigma M_A = 0; \quad B_y(24) + 40 - 8(8) = 0 \quad B_y = 1.00 \text{ kip} \right. \\ \left. + \uparrow \Sigma F_y = 0; \quad A_y + 1.00 - 8 = 0 \quad A_y = 7.00 \text{ kip} \right. \\ \left. \rightarrow \Sigma F_x = 0 \quad A_x = 0 \right. \end{aligned}$$

Internal Forces : Applying the equations of equilibrium to segment AC [FBD (b)], we have

$$\rightarrow \Sigma F_x = 0; \quad N_C = 0 \quad \text{Ans}$$

$$+ \uparrow \Sigma F_y = 0; \quad 7.00 - 8 - V_C = 0 \quad V_C = -1.00 \text{ kip} \quad \text{Ans}$$

$$\left(+ \Sigma M_C = 0; \quad M_C - 7.00(8) = 0 \quad M_C = 56.0 \text{ kip} \cdot \text{ft} \quad \text{Ans} \right.$$

Applying the equations of equilibrium to segment BD [FBD (c)], we have

$$\rightarrow \Sigma F_x = 0; \quad N_D = 0 \quad \text{Ans}$$

$$+ \uparrow \Sigma F_y = 0; \quad V_D + 1.00 = 0 \quad V_D = -1.00 \text{ kip} \quad \text{Ans}$$

$$\left(+ \Sigma M_D = 0; \quad 1.00(8) + 40 - M_D = 0 \right. \\ \left. M_D = 48.0 \text{ kip} \cdot \text{ft} \quad \text{Ans} \right.$$

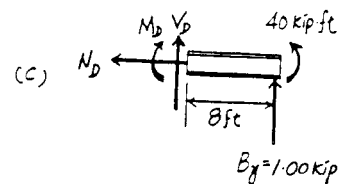
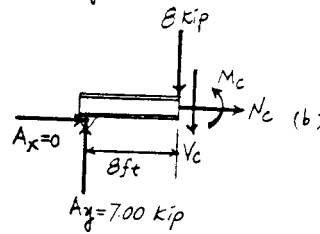
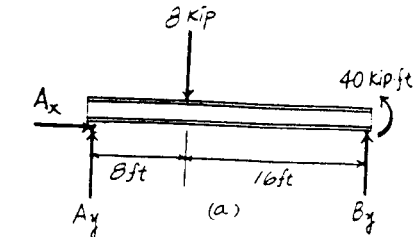

7-7. Determine the shear force and moment at points C and D.

Support Reactions : FBD (a).

$$\left(+ \Sigma M_B = 0; \quad 500(8) - 300(8) - A_y(14) = 0 \right. \\ \left. A_y = 114.29 \text{ lb} \right.$$

Internal Forces : Applying the equations of equilibrium to segment AC [FBD (b)], we have

$$\rightarrow \Sigma F_x = 0; \quad N_C = 0 \quad \text{Ans}$$

$$+ \uparrow \Sigma F_y = 0; \quad 114.29 - 500 - V_C = 0 \quad V_C = -386 \text{ lb} \quad \text{Ans}$$

$$\left(+ \Sigma M_C = 0; \quad M_C + 500(4) - 114.29(10) = 0 \right. \\ \left. M_C = -857 \text{ lb} \cdot \text{ft} \quad \text{Ans} \right.$$

Applying the equations of equilibrium to segment ED [FBD (c)], we have

$$\rightarrow \Sigma F_x = 0; \quad N_D = 0 \quad \text{Ans}$$

$$+ \uparrow \Sigma F_y = 0; \quad V_D - 300 = 0 \quad V_D = 300 \text{ lb} \quad \text{Ans}$$

$$\left(+ \Sigma M_D = 0; \quad -M_D - 300(2) = 0 \quad M_D = -600 \text{ lb} \cdot \text{ft} \quad \text{Ans} \right.$$

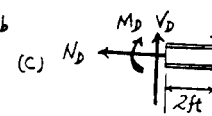
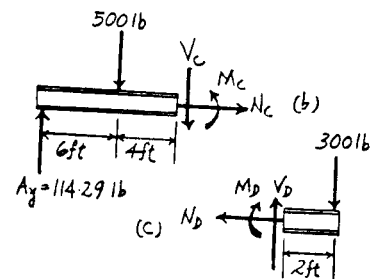
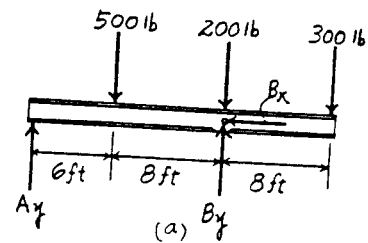
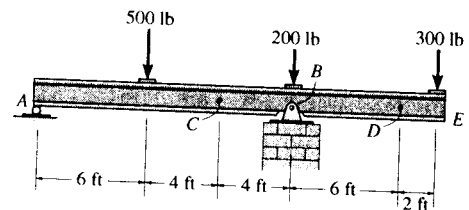

*7-8. Determine the normal force, shear force, and moment at a section passing through point C. Assume the support at A can be approximated by a pin and B as a roller.

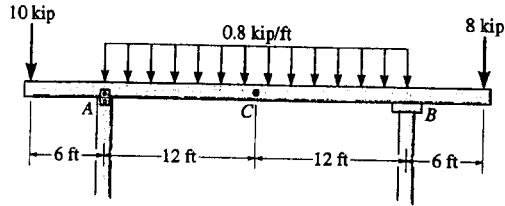

$$\begin{aligned} \zeta + \Sigma M_A = 0; & \quad -19.2(12) - 8(30) + B_y(24) + 10(6) = 0 \\ & \quad B_y = 17.1 \text{ kip} \\ \rightarrow \Sigma F_x = 0; & \quad A_x = 0 \\ + \uparrow \Sigma F_y = 0; & \quad A_y - 10 - 19.2 + 17.1 - 8 = 0 \\ & \quad A_y = 20.1 \text{ kip} \\ \rightarrow \Sigma F_x = 0; & \quad N_C = 0 \quad \text{Ans} \\ + \uparrow \Sigma F_y = 0; & \quad V_C - 9.6 + 17.1 - 8 = 0 \\ & \quad V_C = 0.5 \text{ kip} \quad \text{Ans} \\ \zeta + \Sigma M_C = 0; & \quad -M_C - 9.6(6) + 17.1(12) - 8(18) = 0 \\ & \quad M_C = 3.6 \text{ kip}\cdot\text{ft} \quad \text{Ans} \end{aligned}$$

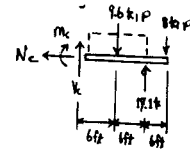
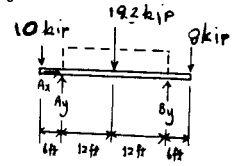

7-9. Determine the normal force, shear force, and moment at a section passing through point D. Take $w = 150 \text{ N/m}$.

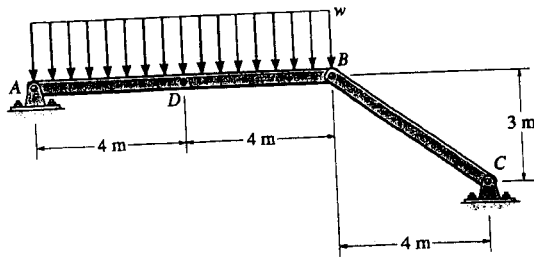

$$\begin{aligned} \zeta + \Sigma M_A = 0; & \quad -150(8)(4) + \frac{3}{5}F_{BC}(8) = 0 \\ & \quad F_{BC} = 1000 \text{ N} \\ \rightarrow \Sigma F_x = 0; & \quad A_x - \frac{4}{5}(1000) = 0 \\ & \quad A_x = 800 \text{ N} \\ + \uparrow \Sigma F_y = 0; & \quad A_y - 150(8) + \frac{3}{5}(1000) = 0 \\ & \quad A_y = 600 \text{ N} \\ \rightarrow \Sigma F_x = 0; & \quad N_D = -800 \text{ N} \\ + \uparrow \Sigma F_y = 0; & \quad 600 - 150(4) - V_D = 0 \\ & \quad V_D = 0 \\ \zeta + \Sigma M_D = 0; & \quad -600(4) + 150(4)(2) + M_D = 0 \\ & \quad M_D = 1200 \text{ N}\cdot\text{m} = 1.20 \text{ kN}\cdot\text{m} \quad \text{Ans} \end{aligned}$$

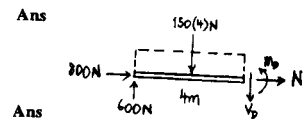
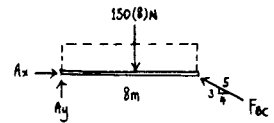

7-10. The beam AB will fail if the maximum internal moment at D reaches $800 \text{ N}\cdot\text{m}$ or the normal force in member BC becomes 1500 N . Determine the largest load w it can support.

Assume maximum moment occurs at D ;

$$\zeta + \Sigma M_D = 0; \quad M_D - 4w(2) = 0$$

$$800 = 4w(2)$$

$$w = 100 \text{ N/m}$$

$$\zeta + \Sigma M_A = 0; \quad -800(4) + T_{BC}(0.6)(8) = 0$$

$$T_{BC} = 666.7 \text{ N} < 1500 \text{ N} \quad (\text{O.K.})$$

$$w = 100 \text{ N/m}$$

Ans

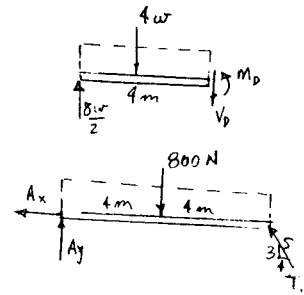
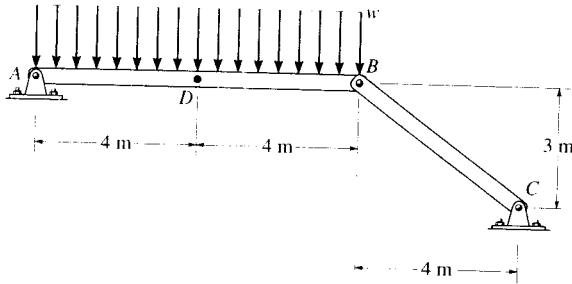

7-11. Determine the shear force and moment acting at a section passing through point C in the beam.

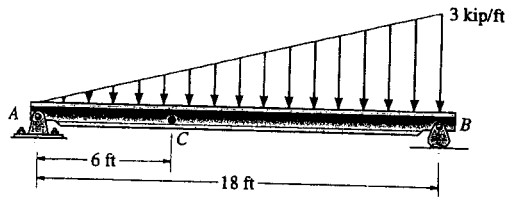

$$\zeta + \Sigma M_B = 0; \quad -A_y(18) + 27(6) = 0$$

$$A_y = 9 \text{ kip}$$

$$\rightarrow \Sigma F_x = 0; \quad A_x = 0$$

$$\zeta + \Sigma M_C = 0; \quad -9(6) + 3(2) + M_C = 0$$

$$M_C = 48 \text{ kip}\cdot\text{ft} \quad \text{Ans}$$

$$+ \uparrow \Sigma F_y = 0; \quad 9 - 3 - V_C = 0$$

$$V_C = 6 \text{ kip} \quad \text{Ans}$$

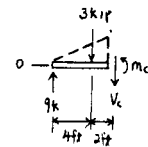
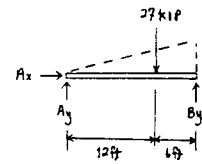

*7-12. The boom DF of the jib crane and the column DE have a uniform weight of 50 lb/ft. If the hoist and load weigh 300 lb, determine the normal force, shear force, and moment in the crane at sections passing through points A , B , and C .

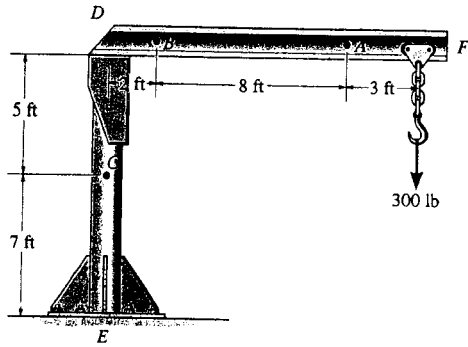

$$\begin{aligned} \rightarrow \Sigma F_x = 0; \quad N_A &= 0 && \text{Ans} \\ + \uparrow \Sigma F_y = 0; \quad V_A - 450 &= 0; \quad V_A = 450 \text{ lb} && \text{Ans} \\ \curvearrowleft + \Sigma M_A = 0; \quad M_A - 150(1.5) - 300(3) &= 0; \quad M_A = 1125 \text{ lb}\cdot\text{ft} && \text{Ans} \\ \rightarrow \Sigma F_x = 0; \quad N_B &= 0 && \text{Ans} \\ + \uparrow \Sigma F_y = 0; \quad V_B - 550 - 300 &= 0; \quad V_B = 850 \text{ lb} && \text{Ans} \\ \curvearrowleft + \Sigma M_B = 0; \quad M_B - 550(5.5) - 300(11) &= 0; \quad M_B = 6325 \text{ lb}\cdot\text{ft} && \text{Ans} \\ \rightarrow \Sigma F_x = 0; \quad V_C &= 0 && \text{Ans} \\ + \uparrow \Sigma F_y = 0; \quad N_C - 650 - 300 - 250 &= 0; \quad N_C = 1200 \text{ lb} && \text{Ans} \\ \curvearrowleft + \Sigma M_C = 0; \quad M_C - 650(6.5) - 300(13) &= 0; \quad M_C = 8125 \text{ lb}\cdot\text{ft} && \text{Ans} \end{aligned}$$

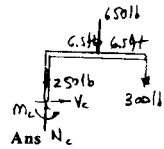
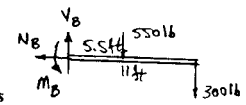
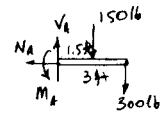

7-13. Determine the internal normal force, shear force, and moment acting at point C and at point D , which is located just to the right of the roller support at B .

Support Reactions : From FBD (a),

$$\begin{aligned} \curvearrowleft + \Sigma M_A = 0; \quad B_y(8) + 800(2) - 2400(4) - 800(10) &= 0 \\ B_y &= 2000 \text{ lb} \end{aligned}$$

Internal Forces : Applying the equations of equilibrium to segment ED [FBD (b)], we have

$$\begin{aligned} \rightarrow \Sigma F_x = 0; \quad N_D &= 0 && \text{Ans} \\ + \uparrow \Sigma F_y = 0; \quad V_D - 800 &= 0 \quad V_D = 800 \text{ lb} && \text{Ans} \\ \curvearrowleft + \Sigma M_D = 0; \quad -M_D - 800(2) &= 0 \\ M_D &= -1600 \text{ lb}\cdot\text{ft} = -1.60 \text{ kip}\cdot\text{ft} && \text{Ans} \end{aligned}$$

Applying the equations of equilibrium to segment EC [FBD (c)], we have

$$\begin{aligned} \rightarrow \Sigma F_x = 0; \quad N_C &= 0 && \text{Ans} \\ + \uparrow \Sigma F_y = 0; \quad V_C + 2000 - 1200 - 800 &= 0 \quad V_C = 0 && \text{Ans} \\ \curvearrowleft + \Sigma M_C = 0; \quad 2000(4) - 1200(2) - 800(6) - M_C &= 0 \\ M_C &= 800 \text{ lb}\cdot\text{ft} && \text{Ans} \end{aligned}$$

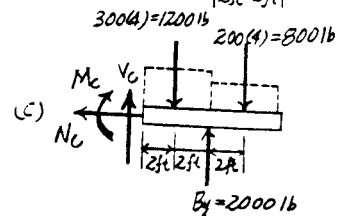
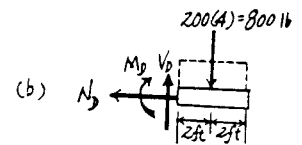
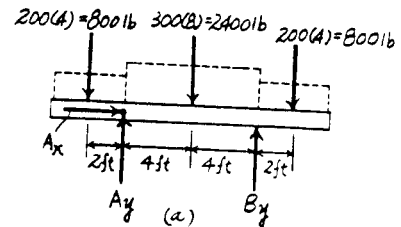
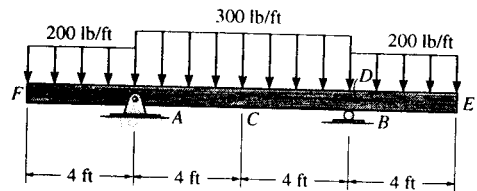

7-14. Determine the normal force, shear force, and moment at a section passing through point D of the two-member frame.

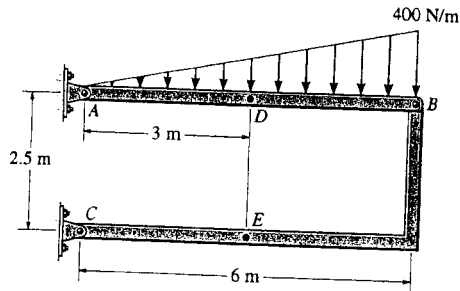

$$\begin{aligned} \zeta + \Sigma M_A = 0; & \quad -1200(4) + \frac{5}{13}F_{BC}(6) = 0 \\ & \quad F_{BC} = 2080 \text{ N} \\ \rightarrow \Sigma F_x = 0; & \quad \frac{12}{13}(2080) - A_x = 0 \\ & \quad A_x = 1920 \text{ N} \\ + \uparrow \Sigma F_y = 0; & \quad A_y - 1200 + \frac{5}{13}(2080) = 0 \\ & \quad A_y = 400 \text{ N} \\ \rightarrow \Sigma F_x = 0; & \quad N_D = 1920 \text{ N} = 1.92 \text{ kN} \\ + \uparrow \Sigma F_y = 0; & \quad 400 - 300 - V_D = 0 \\ & \quad V_D = 100 \text{ N} \\ \zeta + \Sigma M_D = 0; & \quad -400(3) + 300(1) + M_D = 0 \\ & \quad M_D = 900 \text{ N}\cdot\text{m} \end{aligned}$$

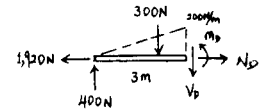
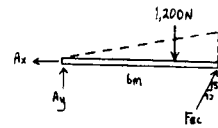

Ans

Ans

Ans

7-15. Determine the normal force, shear force, and moment at a section passing through point E of the two-member frame.

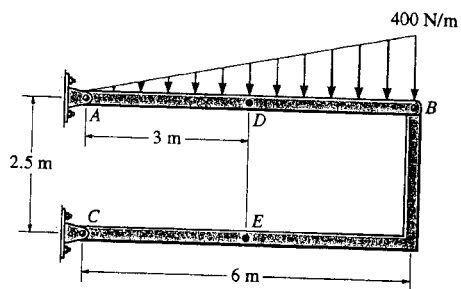

$$\begin{aligned} \zeta + \Sigma M_A = 0; & \quad -1200(4) - \frac{5}{13}F_{BC}(6) = 0 \\ & \quad F_{BC} = 2080 \text{ N} \\ \rightarrow \Sigma F_x = 0; & \quad -N_E - \frac{12}{13}(2080) = 0 \\ & \quad N_E = -1920 \text{ N} = -1.92 \text{ kN} \\ + \uparrow \Sigma F_y = 0; & \quad V_E - \frac{5}{13}(2080) = 0 \\ & \quad V_E = 800 \text{ N} \\ \zeta + \Sigma M_E = 0; & \quad -\frac{5}{13}(2080)(3) + \frac{12}{13}(2080)(2.5) - M_E = 0 \\ & \quad M_E = 2400 \text{ N}\cdot\text{m} = 2.40 \text{ kN}\cdot\text{m} \end{aligned}$$

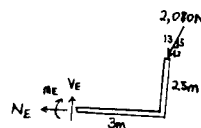
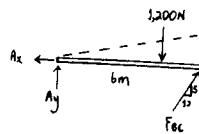

Ans

Ans

Ans

7-16. The strongback or lifting beam is used for materials handling. If the suspended load has a weight of 2 kN and a center of gravity of G , determine the placement d of the padeyes on the top of the beam so that there is no moment developed within the length AB of the beam. The lifting bridle has two legs that are positioned at 45° , as shown.

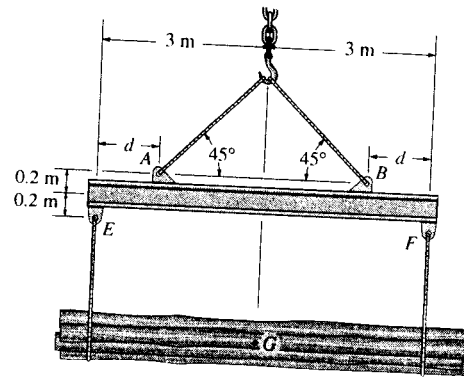

Support Reactions : From FBD (a),

$$\begin{aligned} \curvearrowright + \Sigma M_E = 0; & \quad F_F(6) - 2(3) = 0 & \quad F_F = 1.00 \text{ kN} \\ + \uparrow \Sigma F_y = 0; & \quad F_F + 1.00 - 2 = 0 & \quad F_F = 1.00 \text{ kN} \end{aligned}$$

From FBD (b),

$$\begin{aligned} \rightarrow \Sigma F_x = 0; & \quad F_{AC} \cos 45^\circ - F_{BC} \cos 45^\circ = 0 & \quad F_{AC} = F_{BC} = F \\ + \uparrow \Sigma F_y = 0; & \quad 2F \sin 45^\circ - 1.00 - 1.00 = 0 \\ & \quad F_{AC} = F_{BC} = F = 1.414 \text{ kN} \end{aligned}$$

Internal Forces : This problem requires $M_H = 0$. Summing moments about point H of segment EH [FBD (c)], we have

$$\begin{aligned} \curvearrowright + \Sigma M_H = 0; & \quad 1.00(d+x) - 1.414 \sin 45^\circ(x) \\ & \quad - 1.414 \cos 45^\circ(0.2) = 0 \\ & \quad d = 0.200 \text{ m} \quad \text{Ans} \end{aligned}$$

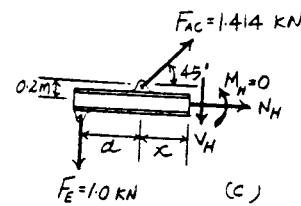
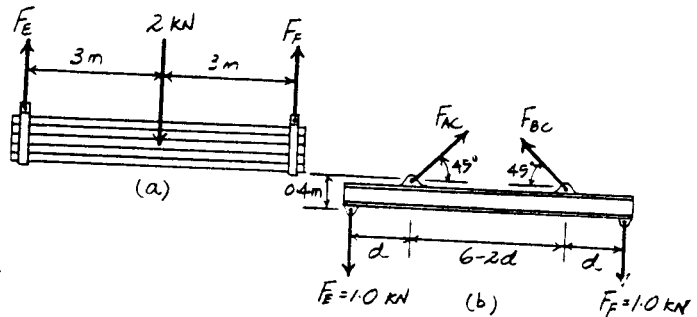

7-17. Determine the normal force, shear force, and moment acting at a section passing through point C.

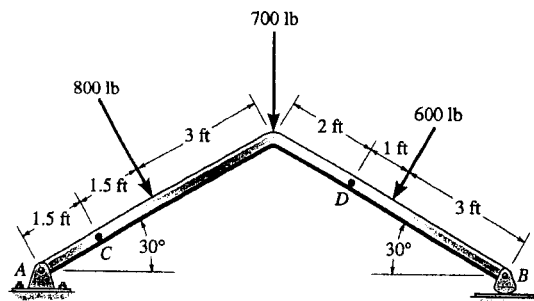

$$\zeta + \Sigma M_A = 0;$$

$$-800(3) - 700(6 \cos 30^\circ) - 600 \cos 30^\circ(6 \cos 30^\circ + 3 \cos 30^\circ) + 600 \sin 30^\circ(3 \sin 30^\circ) + B_y(6 \cos 30^\circ + 6 \cos 30^\circ) = 0$$

$$B_y = 927.4 \text{ lb}$$

$$\rightarrow \Sigma F_x = 0;$$

$$800 \sin 30^\circ - 600 \sin 30^\circ - A_x = 0$$

$$A_x = 100 \text{ lb}$$

$$\uparrow \Sigma F_y = 0;$$

$$A_y - 800 \cos 30^\circ - 700 - 600 \cos 30^\circ + 927.4 = 0$$

$$A_y = 985.1 \text{ lb}$$

$$\swarrow \Sigma F_x = 0;$$

$$N_C - 100 \cos 30^\circ + 985.1 \sin 30^\circ = 0$$

$$N_C = -406 \text{ lb} \quad \text{Ans}$$

$$\nwarrow \Sigma F_y = 0;$$

$$100 \sin 30^\circ + 985.1 \cos 30^\circ - V_C = 0$$

$$V_C = 903 \text{ lb} \quad \text{Ans}$$

$$\zeta + \Sigma M_C = 0;$$

$$-985.1(1.5 \cos 30^\circ) - 100(1.5 \sin 30^\circ) + M_C = 0$$

$$M_C = 1355 \text{ lb}\cdot\text{ft} = 1.35 \text{ kip}\cdot\text{ft} \quad \text{Ans}$$

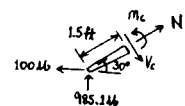
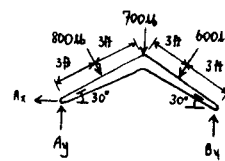

7-18. Determine the normal force, shear force, and moment acting at a section passing through point D.

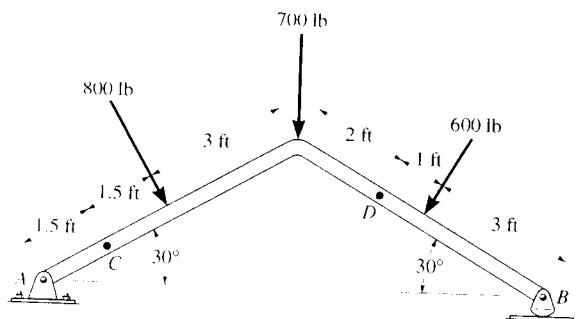

$$\zeta + \Sigma M_A = 0;$$

$$-800(3) - 700(6 \cos 30^\circ) - 600 \cos 30^\circ(6 \cos 30^\circ + 3 \cos 30^\circ) + 600 \sin 30^\circ(3 \sin 30^\circ) + B_y(6 \cos 30^\circ + 6 \cos 30^\circ) = 0$$

$$B_y = 927.4 \text{ lb}$$

$$\rightarrow \Sigma F_x = 0;$$

$$800 \sin 30^\circ - 600 \sin 30^\circ - A_x = 0$$

$$A_x = 100 \text{ lb}$$

$$+ \uparrow \Sigma F_y = 0;$$

$$A_y - 800 \cos 30^\circ - 700 - 600 \cos 30^\circ + 927.4 = 0$$

$$A_y = 985.1 \text{ lb}$$

$$\swarrow \Sigma F_x = 0;$$

$$N_D + 927.4 \sin 30^\circ = 0$$

$$N_D = -464 \text{ lb} \quad \text{Ans}$$

$$\nwarrow \Sigma F_y = 0;$$

$$V_D - 600 + 927.4 \cos 30^\circ = 0$$

$$V_D = -203 \text{ lb} \quad \text{Ans}$$

$$\zeta + \Sigma M_D = 0;$$

$$-M_D - 600(1) + 927.4(4 \cos 30^\circ) = 0$$

$$M_D = 2612 \text{ lb}\cdot\text{ft} = 2.61 \text{ kip}\cdot\text{ft} \quad \text{Ans}$$

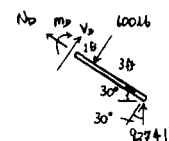
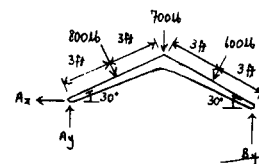

7-19. Determine the normal force, shear force, and moment at a section passing through point C. Take $P = 8 \text{ kN}$.

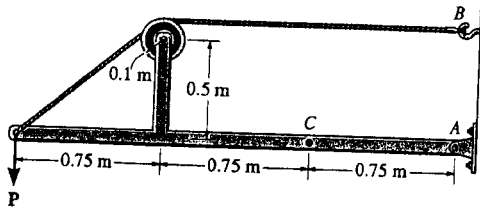

$$\zeta + \Sigma M_A = 0; \quad -T(0.6) + 8(2.25) = 0$$

$$T = 30 \text{ kN}$$

$$\rightarrow \Sigma F_x = 0; \quad A_x = 30 \text{ kN}$$

$$+\uparrow \Sigma F_y = 0; \quad A_y = 8 \text{ kN}$$

$$\rightarrow \Sigma F_x = 0; \quad -N_C - 30 = 0$$

$$N_C = -30 \text{ kN}$$

Ans

$$+\uparrow \Sigma F_y = 0; \quad V_C + 8 = 0$$

$$V_C = -8 \text{ kN}$$

Ans

$$\zeta + \Sigma M_C = 0; \quad -M_C + 8(0.75) = 0$$

$$M_C = 6 \text{ kN}\cdot\text{m}$$

Ans

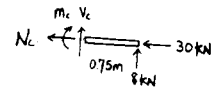
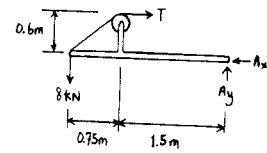

*7-20. The cable will fail when subjected to a tension of 2 kN. Determine the largest vertical load P the frame will support and calculate the internal normal force, shear force, and moment at a section passing through point C for this loading.

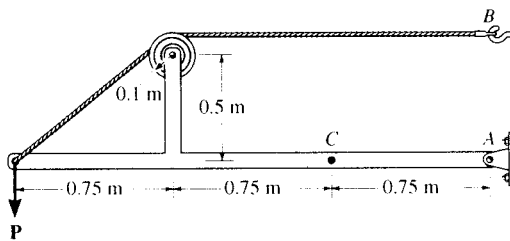

$$\zeta + \Sigma M_A = 0; \quad -2(0.6) + P(2.25) = 0$$

$$P = 0.533 \text{ kN}$$

Ans

$$\rightarrow \Sigma F_x = 0; \quad A_x = 2 \text{ kN}$$

$$+\uparrow \Sigma F_y = 0; \quad A_y = 0.533 \text{ kN}$$

$$\rightarrow \Sigma F_x = 0; \quad -N_C - 2 = 0$$

$$N_C = -2 \text{ kN}$$

Ans

$$+\uparrow \Sigma F_y = 0; \quad -V_C + 0.533 = 0$$

$$V_C = 0.533 \text{ kN}$$

Ans

$$\zeta + \Sigma M_C = 0; \quad -M_C + 0.533(0.75) = 0$$

$$M_C = 0.400 \text{ kN}\cdot\text{m}$$

Ans

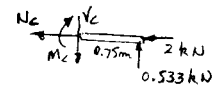
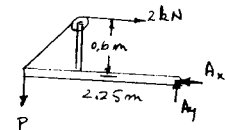

7-21. Determine the internal normal force, shear force, and bending moment in the beam at point B.

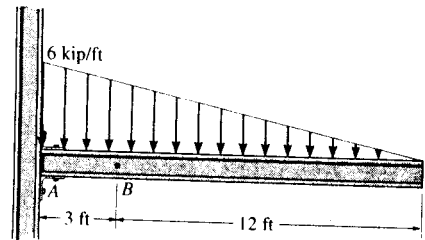

Free body Diagram : The support reactions at A need not be computed.

Internal Forces : Applying the equations of equilibrium to segment CB, we have

$$\begin{aligned} \rightarrow \Sigma F_x = 0; \quad N_B &= 0 && \text{Ans} \\ + \uparrow \Sigma F_y = 0; \quad V_B - 28.8 &= 0 \quad V_B = 28.8 \text{ kip} && \text{Ans} \\ \curvearrowright + \Sigma M_B = 0; \quad -28.8(4) - M_B &= 0 \\ M_B &= -115 \text{ kip} \cdot \text{ft} && \text{Ans} \end{aligned}$$

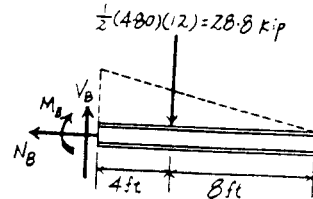

7-22. Determine the ratio of a/b for which the shear force will be zero at the midpoint C of the beam.

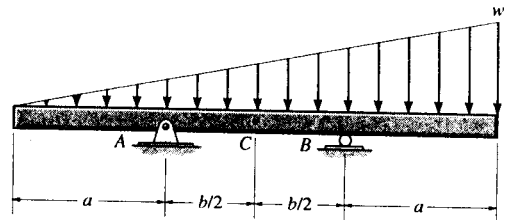

Support Reactions : From FBD (a).

$$\begin{aligned} \curvearrowright + \Sigma M_B = 0; \quad \frac{1}{2}(2a+b)w \left[\frac{1}{3}(b-a) \right] - A_y(b) &= 0 \\ A_y &= \frac{w}{6b}(2a+b)(b-a) \end{aligned}$$

Internal Forces : This problem requires $V_C = 0$. Summing forces vertically [FBD (b)], we have

$$\begin{aligned} + \uparrow \Sigma F_y = 0; \quad \frac{w}{6b}(2a+b)(b-a) - \frac{1}{2}\left(a + \frac{b}{2}\right)\left(\frac{w}{2}\right) &= 0 \\ \frac{w}{6b}(2a+b)(b-a) &= \frac{w}{8}(2a+b) \\ \frac{a}{b} &= \frac{1}{4} \end{aligned}$$

Ans

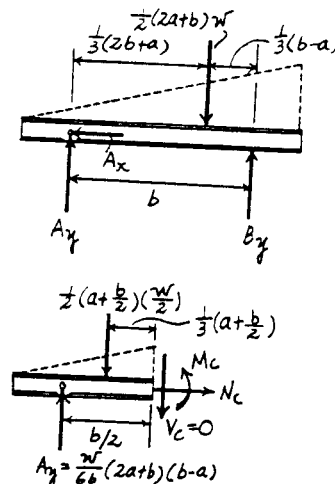

7-23. Determine the internal normal force, shear force, and bending moment at point C.

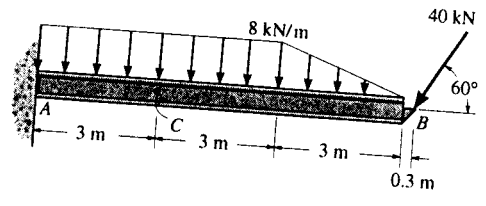

Free body Diagram : The support reactions at A need not be computed.

Internal Forces : Applying equations of equilibrium to segment BC, we have

$$\begin{aligned} \rightarrow \Sigma F_x = 0; & \quad -40 \cos 60^\circ + N_C = 0 \quad N_C = 20.0 \text{ kN} \quad \text{Ans} \\ + \uparrow \Sigma F_y = 0; & \quad V_C - 24.0 - 12.0 - 40 \sin 60^\circ = 0 \\ & \quad V_C = 70.6 \text{ kN} \quad \text{Ans} \\ \curvearrowleft + \Sigma M_C = 0; & \quad -24.0(1.5) - 12.0(4) - 40 \sin 60^\circ (6.3) - M_C = 0 \\ & \quad M_C = -302 \text{ kN} \cdot \text{m} \quad \text{Ans} \end{aligned}$$

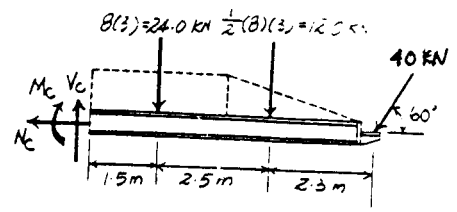

*7-24. The jack AB is used to straighten the bent beam DE using the arrangement shown. If the axial compressive force in the jack is 5000 lb, determine the internal moment developed at point C of the top beam. Neglect the weight of the beams.

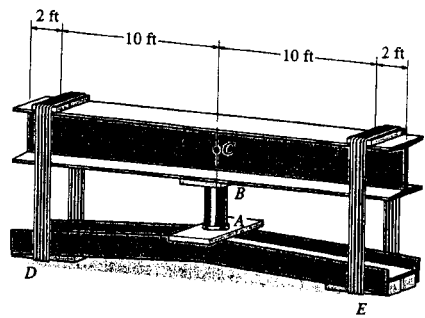

Segment :

$$\begin{aligned} \curvearrowleft + \Sigma M_C = 0; & \quad M_C + 2500(10) = 0 \\ & \quad M_C = -25.0 \text{ kip} \cdot \text{ft} \quad \text{Ans} \end{aligned}$$

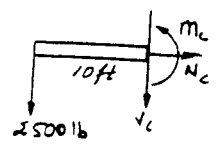
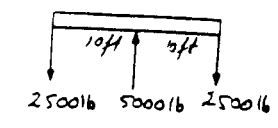

7-25. Solve Prob. 7-24 assuming that each beam has a uniform weight of 150 lb/ft.

Beam :

$$+\uparrow \Sigma F_y = 0; \quad 5000 - 3600 - 2R = 0$$

$$R = 700 \text{ lb}$$

Segment :

$$\curvearrowleft + \Sigma M_C = 0; \quad M_C + 700(10) + 1800(6) = 0$$

$$M_C = -17.8 \text{ kip} \cdot \text{ft} \quad \text{Ans}$$

$$150(24) = 3600 \text{ lb}$$

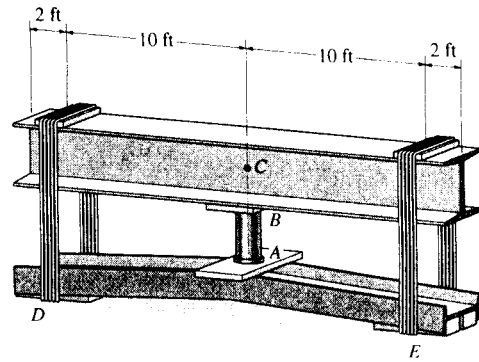
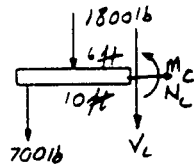
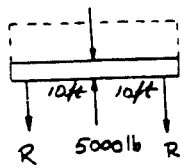

7-26. Determine the normal force, shear force, and moment in the beam at sections passing through points D and E. Point E is just to the right of the 3-kip load.

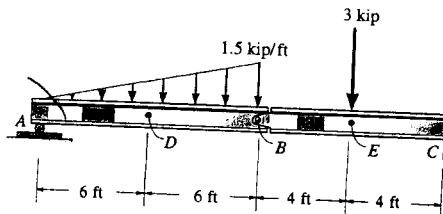

$$\curvearrowleft + \Sigma M_B = 0; \quad \frac{1}{2}(1.5)(12)(4) - A_y(12) = 0$$

$$A_y = 3 \text{ kip}$$

$$\rightarrow \Sigma F_x = 0; \quad B_x = 0$$

$$+\uparrow \Sigma F_y = 0; \quad B_y + 3 - \frac{1}{2}(1.5)(12) = 0$$

$$B_y = 6 \text{ kip}$$

$$\rightarrow \Sigma F_x = 0; \quad N_D = 0 \quad \text{Ans}$$

$$+\uparrow \Sigma F_y = 0; \quad 3 - \frac{1}{2}(0.75)(6) - V_D = 0$$

$$V_D = 0.75 \text{ kip} \quad \text{Ans}$$

$$\curvearrowleft + \Sigma M_D = 0; \quad M_D + \frac{1}{2}(0.75)(6)(2) - 3(6) = 0$$

$$M_D = 13.5 \text{ kip} \cdot \text{ft} \quad \text{Ans}$$

$$\rightarrow \Sigma F_x = 0; \quad N_E = 0 \quad \text{Ans}$$

$$+\uparrow \Sigma F_y = 0; \quad -V_E - 3 - 6 = 0$$

$$V_E = -9 \text{ kip} \quad \text{Ans}$$

$$\Sigma M_E = 0; \quad M_E + 6(4) = 0$$

$$M_E = -24.0 \text{ kip} \cdot \text{ft} \quad \text{Ans}$$

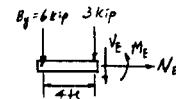
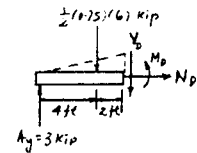
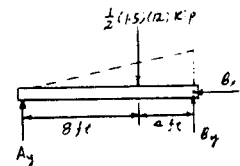

7-27. Determine the normal force, shear force, and moment at a section passing through point D of the two-member frame.

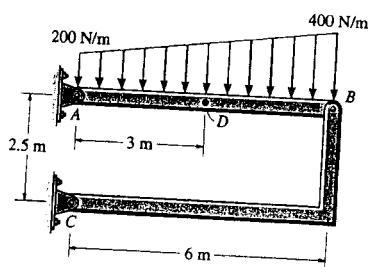

$$\begin{aligned} \zeta + \Sigma M_A = 0; & \quad -1200(3) - 600(4) + \frac{5}{13}F_{BC}(6) = 0 \\ & \quad F_{BC} = 2600 \text{ N} \\ \rightarrow \Sigma F_x = 0; & \quad A_x = \frac{12}{13}(2600) = 2400 \text{ N} \\ + \uparrow \Sigma F_y = 0; & \quad A_y - 1200 - 600 + \frac{5}{13}(2600) = 0 \\ & \quad A_y = 800 \text{ N} \\ \rightarrow \Sigma F_x = 0; & \quad N_D = 2400 \text{ N} = 2.40 \text{ kN} \\ + \uparrow \Sigma F_y = 0; & \quad 800 - 600 - 150 - V_D = 0 \\ & \quad V_D = 50 \text{ N} \\ \zeta + \Sigma M_D = 0; & \quad -800(3) + 600(1.5) + 150(1) + M_D = 0 \\ & \quad M_D = 1350 \text{ N}\cdot\text{m} = 1.35 \text{ kN}\cdot\text{m} \end{aligned}$$

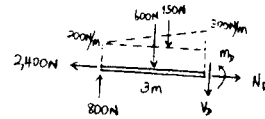
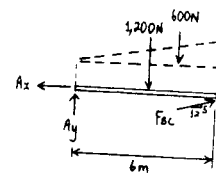

Ans
Ans
Ans
Ans

*7-28. Determine the normal force, shear force, and moment at sections passing through points E and F. Member BC is pinned at B and there is a smooth slot in it at C. The pin at C is fixed to member CD.

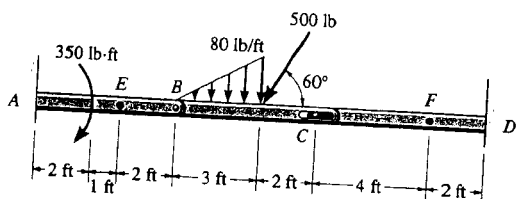

$$\begin{aligned} \zeta + \Sigma M_B = 0; & \quad -120(2) - 500 \sin 60^\circ(3) + C_y(5) = 0 \\ & \quad C_y = 307.8 \text{ lb} \\ \rightarrow \Sigma F_x = 0; & \quad B_x - 500 \cos 60^\circ = 0 \\ & \quad B_x = 250 \text{ lb} \\ + \uparrow \Sigma F_y = 0; & \quad B_y - 120 - 500 \sin 60^\circ + 307.8 = 0 \\ & \quad B_y = 245.2 \text{ lb} \\ \rightarrow \Sigma F_x = 0; & \quad -N_E - 250 = 0 \\ & \quad N_E = -250 \text{ lb} \\ + \uparrow \Sigma F_y = 0; & \quad V_E = 245 \text{ lb} \\ \zeta + \Sigma M_E = 0; & \quad -M_E - 245.2(2) = 0 \\ & \quad M_E = -490 \text{ lb}\cdot\text{ft} \\ \rightarrow \Sigma F_x = 0; & \quad N_F = 0 \\ + \uparrow \Sigma F_y = 0; & \quad -307.8 - V_F = 0 \\ & \quad V_F = -308 \text{ lb} \\ \zeta + \Sigma M_F = 0; & \quad 307.8(4) + M_F = 0 \\ & \quad M_F = -1231 \text{ lb}\cdot\text{ft} = -1.23 \text{ kip}\cdot\text{ft} \end{aligned}$$

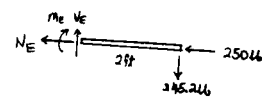
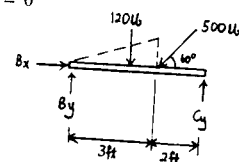

Ans
Ans
Ans
Ans
Ans
Ans

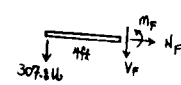

7-29. Determine the internal normal force, shear force, and the moment at points C and D.

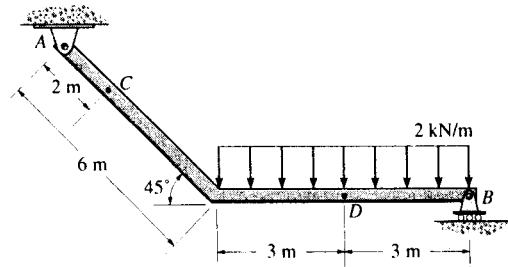

Support Reactions : FBD (a).

$$\begin{aligned} \curvearrowright + \Sigma M_A = 0; & \quad B_y (6 + 6 \cos 45^\circ) - 12.0(3 + 6 \cos 45^\circ) = 0 \\ & \quad B_y = 8.485 \text{ kN} \\ + \uparrow \Sigma F_y = 0; & \quad A_y + 8.485 - 12.0 = 0 \quad A_y = 3.515 \text{ kN} \\ \rightarrow \Sigma F_x = 0 & \quad A_x = 0 \end{aligned}$$

Internal Forces : Applying the equations of equilibrium to segment AC [FBD (b)], we have

$$\begin{aligned} \nearrow \Sigma F_x = 0; & \quad 3.515 \cos 45^\circ - V_C = 0 \quad V_C = 2.49 \text{ kN} \quad \text{Ans} \\ \nwarrow \Sigma F_y = 0; & \quad 3.515 \sin 45^\circ - N_C = 0 \quad N_C = 2.49 \text{ kN} \quad \text{Ans} \\ \curvearrowright + \Sigma M_C = 0; & \quad M_C - 3.515 \cos 45^\circ (2) = 0 \\ & \quad M_C = 4.97 \text{ kN} \cdot \text{m} \quad \text{Ans} \end{aligned}$$

Applying the equations of equilibrium to segment BD [FBD (c)], we have

$$\begin{aligned} \rightarrow \Sigma F_x = 0; & \quad N_D = 0 \quad \text{Ans} \\ + \uparrow \Sigma F_y = 0; & \quad V_D + 8.485 - 6.00 = 0 \quad V_D = -2.49 \text{ kN} \quad \text{Ans} \\ \curvearrowright + \Sigma M_D = 0; & \quad 8.485(3) - 6(1.5) - M_D = 0 \\ & \quad M_D = 16.5 \text{ kN} \cdot \text{m} \quad \text{Ans} \end{aligned}$$

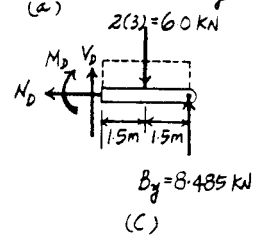
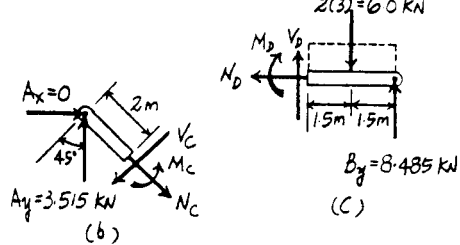
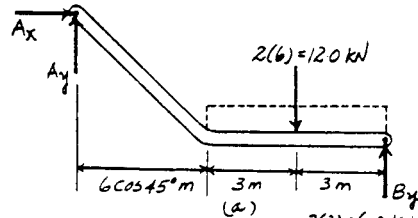

7-30. Determine the normal force, shear force, and moment acting at sections passing through points *B* and *C* on the curved rod.

$$\nearrow + \Sigma F_x = 0; \quad 400 \sin 30^\circ - 300 \cos 30^\circ + N_B = 0$$

$$N_B = 59.8 \text{ lb} \quad \text{Ans}$$

$$+ \searrow \Sigma F_y = 0; \quad V_B + 400 \cos 30^\circ + 300 \sin 30^\circ = 0$$

$$V_B = -496 \text{ lb} \quad \text{Ans}$$

$$\curvearrowleft + \Sigma M_B = 0; \quad M_B + 400(2 \sin 30^\circ)$$

$$+ 300(2 - 2 \cos 30^\circ) = 0$$

$$M_B = -480 \text{ lb}\cdot\text{ft} \quad \text{Ans}$$

Also,

$$\curvearrowleft + \Sigma M_O = 0; \quad -59.81(2) + 300(2) + M_B = 0$$

$$M_B = -480 \text{ lb}\cdot\text{ft} \quad \text{Ans}$$

$$\rightarrow \Sigma F_x = 0; \quad A_x = 400 \text{ lb}$$

$$+ \uparrow \Sigma F_y = 0; \quad A_y = 300 \text{ lb}$$

$$\curvearrowleft + \Sigma M_A = 0; \quad M_A - 300(4) = 0$$

$$M_A = 1200 \text{ lb}\cdot\text{ft}$$

$$+ \searrow \Sigma F_x = 0; \quad N_C + 400 \sin 45^\circ + 300 \cos 45^\circ = 0$$

$$N_C = -495 \text{ lb} \quad \text{Ans}$$

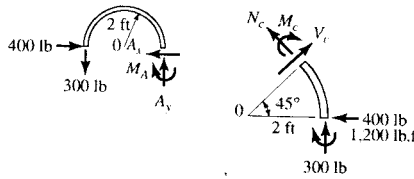
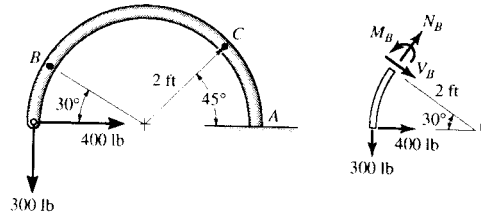

$$\nearrow + \Sigma F_y = 0; \quad V_C - 400 \cos 45^\circ + 300 \sin 45^\circ = 0$$

$$V_C = 70.7 \text{ lb} \quad \text{Ans}$$

$$\curvearrowleft + \Sigma M_C = 0; \quad -M_C - 1200 - 400(2 \sin 45^\circ)$$

$$+ 300(2 - 2 \cos 45^\circ) = 0$$

$$M_C = -1590 \text{ lb}\cdot\text{ft} = -1.59 \text{ kip}\cdot\text{ft} \quad \text{Ans}$$

Also,

$$\curvearrowleft + \Sigma M_O = 0; \quad 495.0(2) + 300(2) + M_C = 0$$

$$M_C = -1590 \text{ lb}\cdot\text{ft} = -1.59 \text{ kip}\cdot\text{ft} \quad \text{Ans}$$

7-31. The cantilevered rack is used to support each end of a smooth pipe that has a total weight of 300 lb. Determine the normal force, shear force, and moment that act in the arm at its fixed support *A* along a vertical section.

Pipe:

$$+ \uparrow \Sigma F_x = 0; \quad N_B \cos 30^\circ - 150 = 0$$

$$N_B = 173.205 \text{ lb}$$

Rack:

$$\rightarrow \Sigma F_x = 0; \quad -N_A + 173.205 \sin 30^\circ = 0$$

$$N_A = 86.6 \text{ lb} \quad \text{Ans}$$

$$+ \uparrow \Sigma F_y = 0; \quad V_A - 173.205 \cos 30^\circ = 0$$

$$V_A = 150 \text{ lb} \quad \text{Ans}$$

$$\curvearrowleft + \Sigma M_A = 0; \quad M_A - 173.205(10.3923) = 0$$

$$M_A = 1800 \text{ lb}\cdot\text{in.} \quad \text{Ans}$$

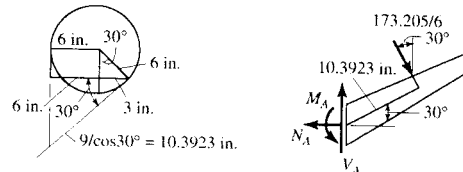
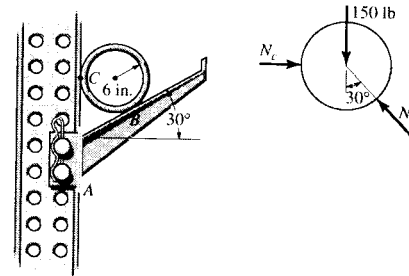

*7-32. Determine the normal force, shear force, and moment at a section passing through point D of the two-member frame.

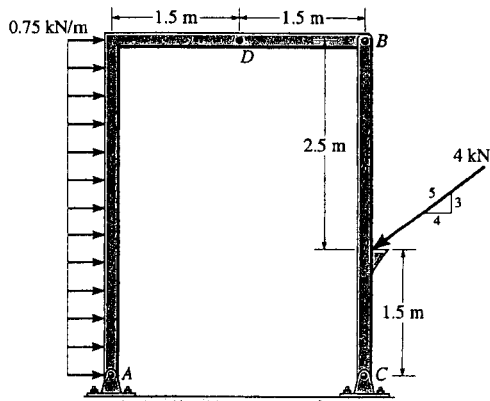

$$\begin{aligned} \curvearrowleft + \Sigma M_A = 0; & \quad -3(2) + B_y(3) + B_x(4) = 0 \\ \curvearrowleft + \Sigma M_C = 0; & \quad -B_x(4) + \frac{4}{5}(4)(1.5) = 0 \\ & \quad B_x = 1.2 \text{ kN} \\ & \quad B_y = 0.4 \text{ kN} \\ \rightarrow \Sigma F_x = 0; & \quad -N_D - 1.2 = 0 \\ & \quad N_D = -1.2 \text{ kN} \\ + \uparrow \Sigma F_y = 0; & \quad V_D + 0.4 = 0 \\ & \quad V_D = -0.4 \text{ kN} \\ \curvearrowleft + \Sigma M_D = 0; & \quad -M_D + 0.4(1.5) = 0 \\ & \quad M_D = 0.6 \text{ kN}\cdot\text{m} \end{aligned}$$

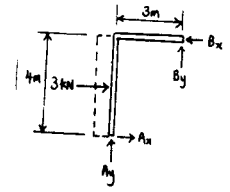

Ans

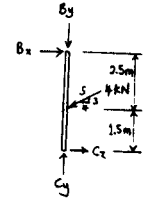

Ans

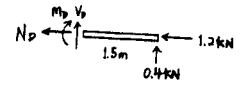

Ans

7-33. Determine the internal normal force, shear force, and bending moment in the beam at points D and E . Point E is just to the right of the 4-kip load. Assume A is a roller support, the splice at B is a pin, and C is a fixed support.

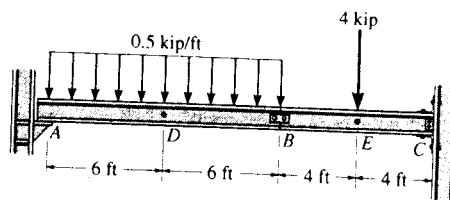

Support Reactions : Support reactions at C need not be computed for this case. From FBD (a),

$$\begin{aligned} \left(+ \Sigma M_B = 0; \quad 6.00(6) - A_y(12) = 0 \quad A_y = 3.00 \text{ kN} \right. \\ \left. + \uparrow \Sigma F_y = 0; \quad B_y + 3.00 - 6.00 = 0 \quad B_y = 3.00 \text{ kN} \right. \\ \left. \rightarrow \Sigma F_x = 0 \quad B_x = 0 \right. \end{aligned}$$

Internal Forces : Applying the equations of equilibrium to segment AD [FBD (b)], we have

$$\begin{aligned} \rightarrow \Sigma F_x = 0; \quad N_D = 0 \quad \text{Ans} \\ + \uparrow \Sigma F_y = 0; \quad 3.00 - 3.00 - V_D = 0 \quad V_D = 0 \quad \text{Ans} \\ \left(+ \Sigma M_D = 0; \quad M_D - 3.00(3) = 0 \quad M_D = 9.00 \text{ kN} \cdot \text{m} \quad \text{Ans} \right. \end{aligned}$$

Applying the equations of equilibrium to segment BE [FBD (c)], we have

$$\begin{aligned} \rightarrow \Sigma F_x = 0; \quad N_E = 0 \quad \text{Ans} \\ + \uparrow \Sigma F_y = 0; \quad -3.00 - 4 - V_E = 0 \quad V_E = -7.00 \text{ kN} \quad \text{Ans} \\ \left(+ \Sigma M_E = 0; \quad M_E + 3.00(4) = 0 \quad M_E = -12.0 \text{ kN} \cdot \text{m} \quad \text{Ans} \right. \end{aligned}$$

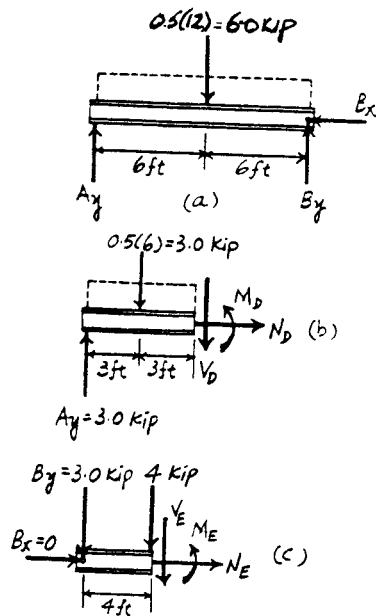

7-34. Determine the internal normal force, shear force, and bending moment at points *E* and *F* of the frame.

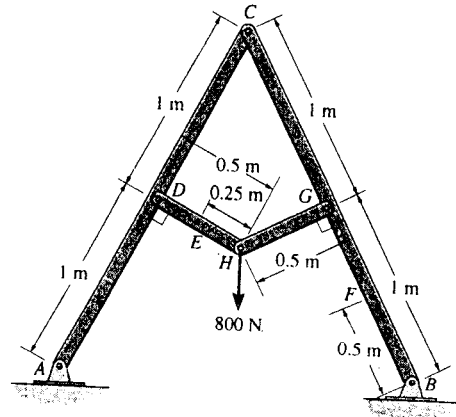

Support Reactions : Members *HD* and *HG* are two force members. Using method of joint [FBD (a)], we have

$$\begin{aligned} \rightarrow \Sigma F_x = 0 & \quad F_{HG} \cos 26.57^\circ - F_{HD} \cos 26.57^\circ = 0 \\ & \quad F_{HD} = F_{HG} = F \\ + \uparrow \Sigma F_y = 0; & \quad 2F \sin 26.57^\circ - 800 = 0 \\ & \quad F_{HD} = F_{HG} = F = 894.43 \text{ N} \end{aligned}$$

From FBD (b),

$$\left(+ \Sigma M_A = 0; \quad C_x (2 \cos 26.57^\circ) + C_y (2 \sin 26.57^\circ) - 894.43 (1) = 0 \quad [1] \right.$$

From FBD (c),

$$\left(+ \Sigma M_B = 0; \quad 894.43 (1) - C_x (2 \cos 26.57^\circ) + C_y (2 \sin 26.57^\circ) = 0 \quad [2] \right.$$

Solving Eqs. [1] and [2] yields,

$$C_y = 0 \quad C_x = 500 \text{ N}$$

Internal Forces : Applying the equations of equilibrium to segment *DE* [FBD (d)], we have

$$+ \Sigma F_x = 0; \quad V_E = 0 \quad \text{Ans}$$

$$+ \Sigma F_y = 0; \quad 894.43 - N_E = 0 \quad N_E = 894 \text{ N} \quad \text{Ans}$$

$$\left(+ \Sigma M_E = 0; \quad M_E = 0 \quad \text{Ans} \right.$$

Applying the equations of equilibrium to segment *CF* [FBD (e)], we have

$$\begin{aligned} + \uparrow \Sigma F_x = 0; & \quad V_F + 500 \cos 26.57^\circ - 894.43 = 0 \\ & \quad V_F = 447 \text{ N} \quad \text{Ans} \end{aligned}$$

$$\downarrow + \Sigma F_y = 0; \quad N_F - 500 \sin 26.57^\circ = 0 \quad N_F = 224 \text{ N} \quad \text{Ans}$$

$$\left(+ \Sigma M_F = 0; \quad M_F + 894.43 (0.5) - 500 \cos 26.57^\circ (1.5) = 0 \right. \\ \left. M_F = 224 \text{ N} \cdot \text{m} \quad \text{Ans} \right.$$

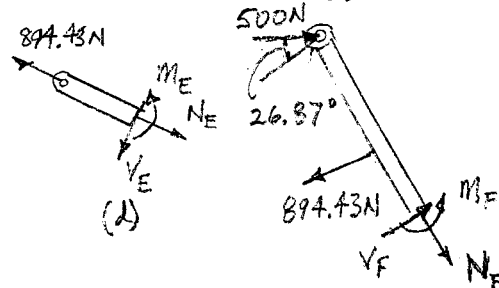
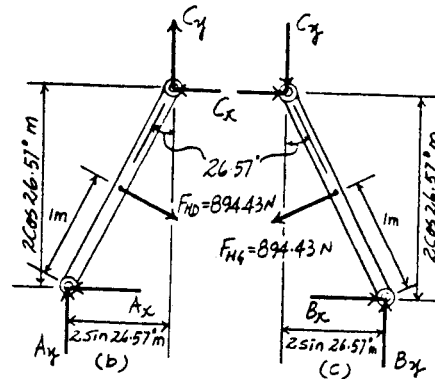
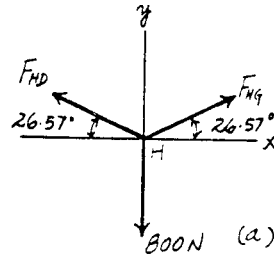

7-35. Draw the shear and moment diagrams for the beam (a) in terms of the parameters shown; (b) set $P = 800$ lb, $a = 5$ ft, $L = 12$ ft.

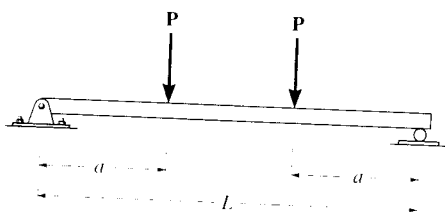

(a) For $0 \leq x < a$

$+\uparrow \Sigma F_y = 0; \quad V = P \quad \text{Ans}$

$(+\Sigma M = 0; \quad M = Px \quad \text{Ans}$

For $a < x < L - a$

$+\uparrow \Sigma F_y = 0; \quad V = 0 \quad \text{Ans}$

$(+\Sigma M = 0; \quad -Px + P(x-a) + M = 0$

$M = Pa \quad \text{Ans}$

For $L - a < x \leq L$

$+\uparrow \Sigma F_y = 0; \quad V = -P \quad \text{Ans}$

$(+\Sigma M = 0; \quad -M + P(L-x) = 0$

$M = P(L-x) \quad \text{Ans}$

(b) Set $P = 800$ lb, $a = 5$ ft, $L = 12$ ft

For $0 \leq x \leq 5$ ft

$+\uparrow \Sigma F_y = 0; \quad V = 800 \text{ lb} \quad \text{Ans}$

$(+\Sigma M = 0; \quad M = 800x \text{ lb}\cdot\text{ft} \quad \text{Ans}$

For $5 \text{ ft} < x < 7 \text{ ft}$

$+\uparrow \Sigma F_y = 0; \quad V = 0 \quad \text{Ans}$

$(+\Sigma M = 0; \quad -800x + 800(x-5) + M = 0$

$M = 4000 \text{ lb}\cdot\text{ft} \quad \text{Ans}$

For $7 \text{ ft} < x \leq 12 \text{ ft}$

$+\uparrow \Sigma F_y = 0; \quad V = -800 \text{ lb} \quad \text{Ans}$

$(+\Sigma M = 0; \quad -M + 800(12-x) = 0$

$M = (9600 - 800x) \text{ lb}\cdot\text{ft} \quad \text{Ans}$

7-35. Determine the distance a as a fraction of the beam's length L for locating the roller support so that the moment in the beam at B is zero.

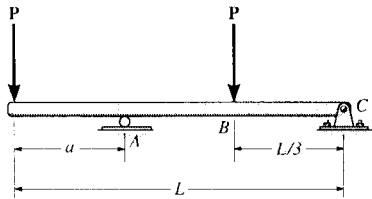

$$\curvearrowleft +\Sigma M_A = 0; \quad -P\left(\frac{2L}{3} - a\right) + C_y(L - a) + Pa = 0$$

$$C_y = \frac{2P\left(\frac{L}{3} - a\right)}{L - a}$$

$$\curvearrowleft +\Sigma M = 0; \quad M = \frac{2P\left(\frac{L}{3} - a\right)}{L - a} \left(\frac{L}{3}\right) = 0$$

$$2PL\left(\frac{L}{3} - a\right) = 0$$

$$a = \frac{L}{3}$$

Ans

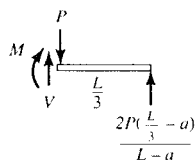
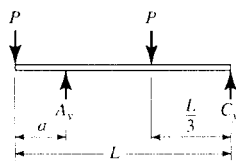

*7-36. The semicircular arch is subjected to a uniform distributed load along its axis of w_0 per unit length. Determine the internal normal force, shear force, and moment in the arch at $\theta = 45^\circ$.

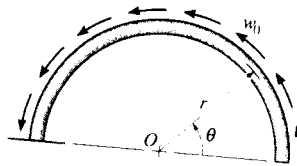

Resultants of distributed load:

$$F_{Rx} = \int_0^\pi w_0(r d\theta) \sin \theta = r w_0 (-\cos \theta) \Big|_0^\pi = r w_0 (1 - \cos \theta)$$

$$F_{Ry} = \int_0^\pi w_0(r d\theta) \cos \theta = r w_0 (\sin \theta) \Big|_0^\pi = r w_0 (\sin \theta)$$

$$M_{R_0} = \int_0^\pi w_0(r d\theta) r = r^2 w_0 \theta$$

At $\theta = 45^\circ$

$$\uparrow \Sigma F_x = 0: -V + F_{Rx} \cos \theta - F_{Ry} \sin \theta = 0$$

$$V = 0.2929 r w_0 \cos 45^\circ - 0.707 r w_0 \sin 45^\circ$$

$$V = -0.293 r w_0 \quad \text{Ans}$$

$$\rightarrow \Sigma F_y = 0: N + F_{Ry} \cos \theta + F_{Rx} \sin \theta = 0$$

$$N = -0.707 r w_0 \sin 45^\circ - 0.2929 r w_0 \cos 45^\circ$$

$$N = -0.707 r w_0 \quad \text{Ans}$$

$$\curvearrowleft \Sigma M_0 = 0: -M + r^2 w_0 \left(\frac{\pi}{4}\right) + (-0.707 r w_0)(r) = 0$$

$$M = -0.0783 r^2 w_0 \quad \text{Ans}$$

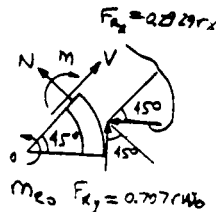
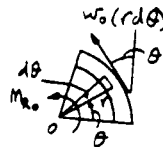

7-37. Solve Prob. 7-36 for $\theta = 120^\circ$.

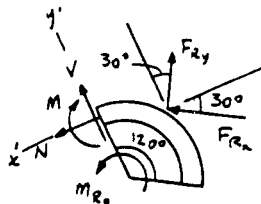
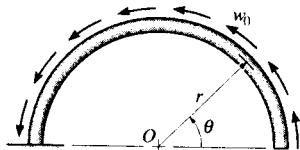

Resultants of distributed load:

$$F_{Rx} = \int_0^\pi w_0(r d\theta) \sin \theta = r w_0 (-\cos \theta) \Big|_0^\pi = r w_0 (1 - \cos \theta)$$

$$F_{Ry} = \int_0^\pi w_0(r d\theta) \cos \theta = r w_0 (\sin \theta) \Big|_0^\pi = r w_0 (\sin \theta)$$

$$M_{R_0} = \int_0^\pi w_0(r d\theta) r = r^2 w_0 \theta$$

At $\theta = 120^\circ$,

$$F_{Rx} = r w_0 (1 - \cos 120^\circ) = 1.5 r w_0$$

$$F_{Ry} = r w_0 \sin 120^\circ = 0.86603 r w_0$$

$$\rightarrow \Sigma F_x = 0: N + 1.5 r w_0 \cos 30^\circ - 0.86603 r w_0 \sin 30^\circ = 0$$

$$N = -0.866 r w_0 \quad \text{Ans}$$

$$\uparrow \Sigma F_y = 0: V + 1.5 r w_0 \sin 30^\circ + 0.86603 r w_0 \cos 30^\circ = 0$$

$$V = -1.5 r w_0 \quad \text{Ans}$$

$$\curvearrowleft \Sigma M_0 = 0: -M + r^2 w_0 \left(\frac{\pi}{3}\right) + (-0.866 r w_0) r = 0$$

$$M = 1.23 r^2 w_0 \quad \text{Ans}$$

7-38. Determine the x , y , z components of internal loading at a section passing through point C in the pipe assembly. Neglect the weight of the pipe. Take $F_1 = \{350\mathbf{j} - 400\mathbf{k}\}$ lb and $F_2 = \{150\mathbf{i} - 300\mathbf{k}\}$ lb.

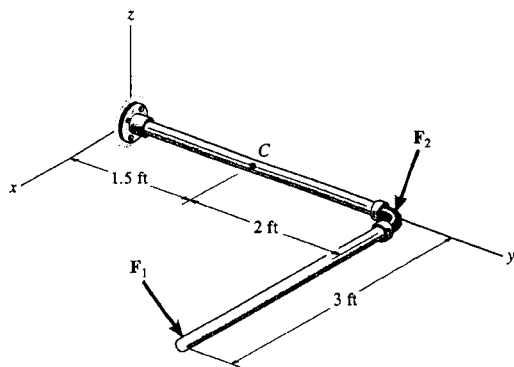

$$\Sigma M_x = 0;$$

$$M_C + r_{C1} \times F_1 + r_{C2} \times F_2 = 0$$

$$M_C + \begin{vmatrix} \mathbf{i} & \mathbf{j} & \mathbf{k} \\ 3 & 2 & 0 \\ 0 & 350 & -400 \end{vmatrix} + \begin{vmatrix} \mathbf{i} & \mathbf{j} & \mathbf{k} \\ 0 & 2 & 0 \\ 150 & 0 & -300 \end{vmatrix} = 0$$

$$M_C = \{1400\mathbf{i} - 1200\mathbf{j} - 750\mathbf{k}\} \text{ lb}\cdot\text{ft}$$

$$M_{Cx} = 1.40 \text{ kip}\cdot\text{ft} \quad \text{Ans}$$

$$M_{Cy} = -1.20 \text{ kip}\cdot\text{ft} \quad \text{Ans}$$

$$M_{Cz} = -750 \text{ lb}\cdot\text{ft} \quad \text{Ans}$$

$$\Sigma F_R = 0; \quad F_C + F_1 + F_2 = 0$$

$$F_C = \{-150\mathbf{i} - 350\mathbf{j} + 700\mathbf{k}\} \text{ lb}$$

$$C_x = -150 \text{ lb} \quad \text{Ans}$$

$$C_y = -350 \text{ lb} \quad \text{Ans}$$

$$C_z = 700 \text{ lb} \quad \text{Ans}$$

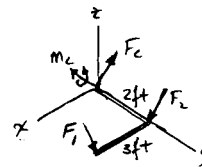

7-39. Determine the x , y , z components of internal loading at a section passing through point C in the pipe assembly. Neglect the weight of the pipe. Take $F_1 = \{-80\mathbf{i} + 200\mathbf{j} - 300\mathbf{k}\}$ lb and $F_2 = \{250\mathbf{i} - 150\mathbf{j} - 200\mathbf{k}\}$ lb.

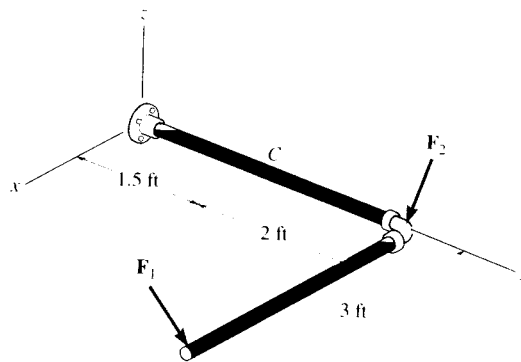

$$\Sigma F_R = 0; \quad F_C + F_1 + F_2 = 0$$

$$F_C = \{-170\mathbf{i} - 50\mathbf{j} + 500\mathbf{k}\} \text{ lb}$$

$$C_x = -170 \text{ lb} \quad \text{Ans}$$

$$C_y = -50 \text{ lb} \quad \text{Ans}$$

$$C_z = 500 \text{ lb} \quad \text{Ans}$$

$$\Sigma M_x = 0;$$

$$M_C + r_{C1} \times F_1 + r_{C2} \times F_2 = 0$$

$$M_C + \begin{vmatrix} \mathbf{i} & \mathbf{j} & \mathbf{k} \\ 3 & 2 & 0 \\ -80 & 200 & -300 \end{vmatrix} + \begin{vmatrix} \mathbf{i} & \mathbf{j} & \mathbf{k} \\ 0 & 2 & 0 \\ 250 & -150 & -200 \end{vmatrix} = 0$$

$$M_C = \{1000\mathbf{i} - 900\mathbf{j} - 260\mathbf{k}\} \text{ lb}\cdot\text{ft}$$

$$M_{Cx} = 1 \text{ kip}\cdot\text{ft} \quad \text{Ans}$$

$$M_{Cy} = -900 \text{ lb}\cdot\text{ft} \quad \text{Ans}$$

$$M_{Cz} = -260 \text{ lb}\cdot\text{ft} \quad \text{Ans}$$

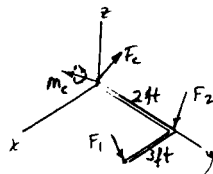

*7-40. Determine the x, y, z components of force and moment at point C in the pipe assembly. Neglect the weight of the pipe. The load acting at $(0, 3.5 \text{ ft}, 3 \text{ ft})$ is $\mathbf{F}_1 = \{-24\mathbf{i} - 10\mathbf{k}\} \text{ lb}$ and $\mathbf{M} = \{-30\mathbf{k}\} \text{ lb} \cdot \text{ft}$ and at point $(0, 3.5 \text{ ft}, 0)$ $\mathbf{F}_2 = \{-80\mathbf{i}\} \text{ lb}$.

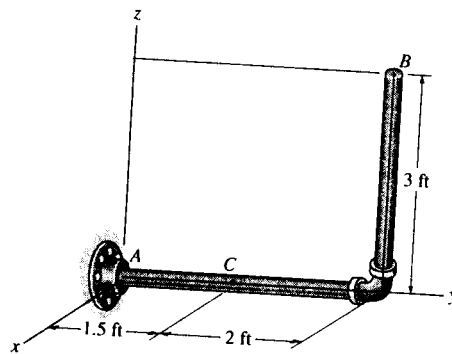

Free body Diagram : The support reactions need not be computed.

Internal Forces : Applying the equations of equilibrium to segment BC , we have

$$\Sigma F_x = 0; \quad (V_C)_x - 24 - 80 = 0 \quad (V_C)_x = 104 \text{ lb} \quad \text{Ans}$$

$$\Sigma F_y = 0; \quad N_C = 0 \quad \text{Ans}$$

$$\Sigma F_z = 0; \quad (V_C)_z - 10 = 0 \quad (V_C)_z = 10.0 \text{ lb} \quad \text{Ans}$$

$$\Sigma M_x = 0; \quad (M_C)_x - 10(2) = 0 \quad (M_C)_x = 20.0 \text{ lb} \cdot \text{ft} \quad \text{Ans}$$

$$\Sigma M_y = 0; \quad (M_C)_y - 24(3) = 0 \quad (M_C)_y = 72.0 \text{ lb} \cdot \text{ft} \quad \text{Ans}$$

$$\Sigma M_z = 0; \quad (M_C)_z + 24(2) + 80(2) - 30 = 0 \\ (M_C)_z = -178 \text{ lb} \cdot \text{ft} \quad \text{Ans}$$

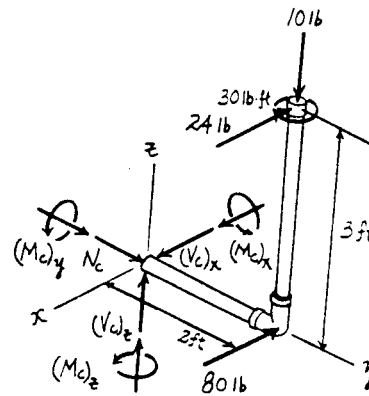

7-41. Determine the x , y , z components of force and moment at point C in the pipe assembly. Neglect the weight of the pipe. Take $\mathbf{F}_1 = \{350\mathbf{i} - 400\mathbf{j}\}$ lb and $\mathbf{F}_2 = \{-300\mathbf{j} + 150\mathbf{k}\}$ lb.

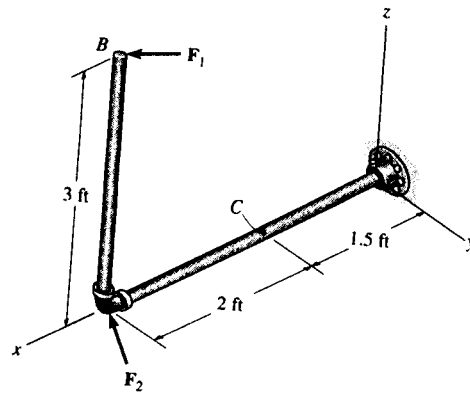

Free body Diagram : The support reactions need not be computed.

Internal Forces : Applying the equations of equilibrium to segment BC , we have

$$\Sigma F_x = 0; \quad N_C + 350 = 0 \quad N_C = -350 \text{ lb} \quad \text{Ans}$$

$$\Sigma F_y = 0; \quad (V_C)_y - 400 - 300 = 0 \quad (V_C)_y = 700 \text{ lb} \quad \text{Ans}$$

$$\Sigma F_z = 0; \quad (V_C)_z + 150 = 0 \quad (V_C)_z = -150 \text{ lb} \quad \text{Ans}$$

$$\Sigma M_x = 0; \quad (M_C)_x + 400(3) = 0 \\ (M_C)_x = -1200 \text{ lb} \cdot \text{ft} = -1.20 \text{ kip} \cdot \text{ft} \quad \text{Ans}$$

$$\Sigma M_y = 0; \quad (M_C)_y + 350(3) - 150(2) = 0 \\ (M_C)_y = -750 \text{ lb} \cdot \text{ft} \quad \text{Ans}$$

$$\Sigma M_z = 0; \quad (M_C)_z - 300(2) - 400(2) = 0 \\ (M_C)_z = 1400 \text{ lb} \cdot \text{ft} = 1.40 \text{ kip} \cdot \text{ft} \quad \text{Ans}$$

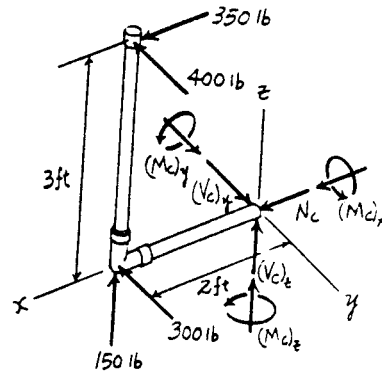

7-42. Draw the shear and moment diagrams for the beam (a) in terms of the parameters shown; (b) set $P = 600$ lb, $a = 5$ ft, $b = 7$ ft.

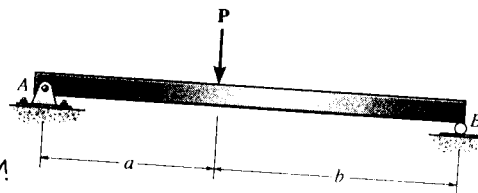

(a) For $0 \leq x < a$

$$+\uparrow \Sigma F_y = 0; \quad \frac{Pb}{a+b} - V = 0$$

$$V = \frac{Pb}{a+b} \quad \text{Ans}$$

$$(+\Sigma M = 0; \quad M - \frac{Pb}{a+b}x = 0$$

$$M = \frac{Pb}{a+b}x \quad \text{Ans}$$

For $a < x \leq (a+b)$

$$+\uparrow \Sigma F_y = 0; \quad \frac{Pb}{a+b} - P - V = 0$$

$$V = -\frac{Pa}{a+b} \quad \text{Ans}$$

$$(+\Sigma M = 0; \quad -\frac{Pb}{a+b}x + P(x-a) + M = 0$$

$$M = Pa - \frac{Pa}{a+b}x \quad \text{Ans}$$

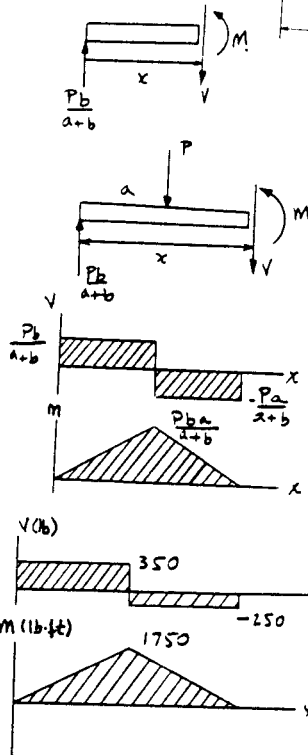

(b) For $P = 600$ lb, $a = 5$ ft, $b = 7$ ft

7-43. Draw the shear and moment diagrams for the cantilevered beam.

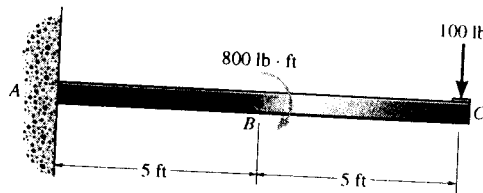
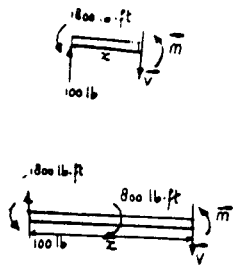

For $0 \leq x < 5$ ft:

$$+\uparrow \Sigma F_y = 0; \quad 100 - V = 0; \quad V = 100 \quad \text{Ans}$$

$$(+\Sigma M = 0; \quad M - 100x + 1800 = 0; \quad M = 100x - 1800 \quad \text{Ans}$$

For $5 < x \leq 10$ ft:

$$+\uparrow \Sigma F_y = 0; \quad 100 - V = 0; \quad V = 100 \quad \text{Ans}$$

$$(+\Sigma M = 0; \quad M - 100x + 1000 = 0; \quad M = 100x - 1000 \quad \text{Ans}$$

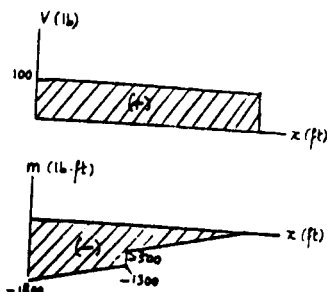
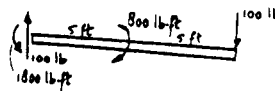

7-44. The suspender bar supports the 600-lb engine.
 Draw the shear and moment diagrams for the bar.

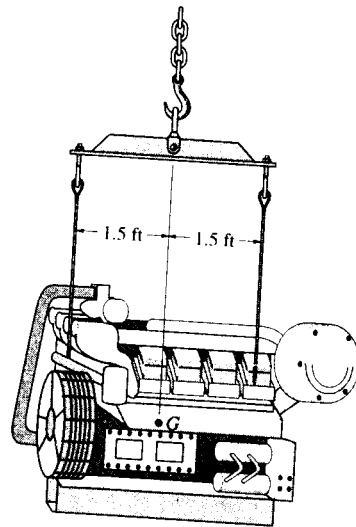

For $0 \leq x < 1.5$ ft:

$$+\uparrow \Sigma F_y = 0: -300 - V = 0$$

$$V = -300 \quad \text{Ans}$$

$$\curvearrowright + \Sigma M = 0: M + 300x = 0$$

$$M = -300x \quad \text{Ans}$$

For $1.5 \text{ ft} < x \leq 3$ ft:

$$+\uparrow \Sigma F_y = 0: 600 - 300 - V = 0$$

$$V = 300 \quad \text{Ans}$$

$$\curvearrowright + \Sigma M = 0: M + 300x - 600(x - 1.5) = 0$$

$$M = 300x - 900 \quad \text{Ans}$$

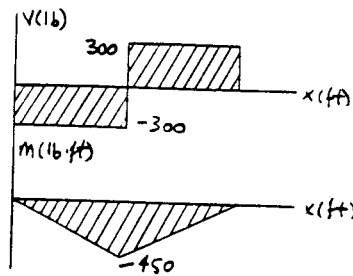
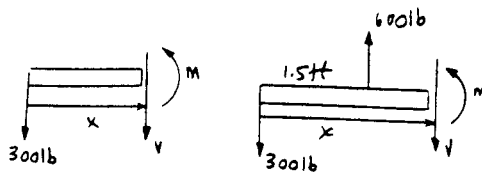

7-45. Draw the shear and moment diagrams for the beam (a) in terms of the parameters shown; (b) set $M_0 = 500 \text{ N}\cdot\text{m}$, $L = 8 \text{ m}$.

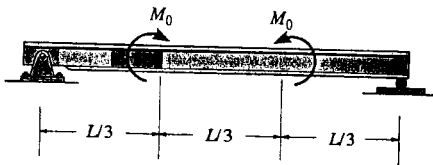

(a) For $0 \leq x \leq \frac{L}{3}$

$+\uparrow \Sigma F_y = 0; \quad V = 0$ Ans

$\zeta + \Sigma M = 0; \quad M = 0$ Ans

For $\frac{L}{3} < x < \frac{2L}{3}$

$+\uparrow \Sigma F_y = 0; \quad V = 0$ Ans

$\zeta + \Sigma M = 0; \quad M = M_0$ Ans

For $\frac{2L}{3} < x \leq L$

$+\uparrow \Sigma F_y = 0; \quad V = 0$ Ans

$\zeta + \Sigma M = 0; \quad M = 0$ Ans

(b) Set $M_0 = 500 \text{ N}\cdot\text{m}$, $L = 8 \text{ m}$

For $0 \leq x < \frac{8}{3} \text{ m}$

$+\uparrow \Sigma F_y = 0; \quad V = 0$ Ans

$\zeta + \Sigma M = 0; \quad M = 0$ Ans

For $\frac{8}{3} \text{ m} < x < \frac{16}{3} \text{ m}$

$+\uparrow \Sigma F_y = 0; \quad V = 0$ Ans

$\zeta + \Sigma M = 0; \quad M = 500 \text{ N}\cdot\text{m}$ Ans

For $\frac{16}{3} \text{ m} < x \leq 8 \text{ m}$

$+\uparrow \Sigma F_y = 0; \quad V = 0$ Ans

$\zeta + \Sigma M = 0; \quad M = 0$ Ans

7-46. If $L = 9 \text{ m}$, the beam will fail when the maximum shear force is $V_{\max} = 5 \text{ kN}$ or the maximum bending moment is $M_{\max} = 2 \text{ kN}\cdot\text{m}$. Determine the magnitude M_0 of the largest couple moments it will support.

See solution to Prob. 7-45

$M_{\max} = M_0 = 2 \text{ kN}\cdot\text{m}$ Ans

7-47. The shaft is supported by a thrust bearing at A and a journal bearing at B . If $L = 10$ ft the shaft will fail when the maximum moment is $M_{\max} = 5$ kip-ft. Determine the largest uniform distributed load w the shaft will support.

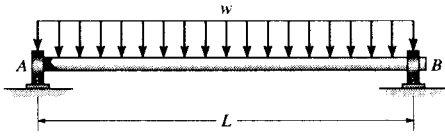

For $0 \leq x \leq L$

$$+\uparrow \Sigma F_y = 0; \quad \frac{wL}{2} - wx - V = 0$$

$$V = -wx + \frac{wL}{2}$$

$$V = \frac{w}{2}(L - 2x)$$

$$\curvearrowleft + \Sigma M = 0; \quad -\frac{wL}{2}x + wx\left(\frac{x}{2}\right) + M = 0$$

$$M = \frac{wL}{2}x - \frac{wx^2}{2}$$

$$M = \frac{w}{2}(Lx - x^2)$$

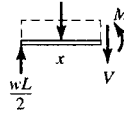

From the moment diagram

$$M_{\max} = \frac{wL^2}{8}$$

$$5000 = \frac{w(10)^2}{8}$$

$$w = 400 \text{ lb/ft} \quad \text{Ans}$$

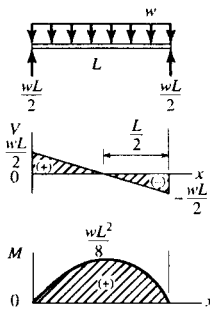

*7-48. Draw the shear and moment diagrams for the beam.

Support Reactions:

$$\curvearrowleft + \Sigma M_A = 0; \quad C_c(3) - 1.5(2.5) = 0 \quad C_c = 1.25 \text{ kN}$$

$$+ \uparrow \Sigma F_y = 0; \quad A_y - 1.5 + 1.25 = 0 \quad A_y = 0.250 \text{ kN}$$

Shear and Moment Functions: For $0 \leq x < 2 \text{ m}$ [FBD (a)],

$$+ \uparrow \Sigma F_y = 0; \quad 0.250 - V = 0 \quad V = 0.250 \text{ kN} \quad \text{Ans}$$

$$\curvearrowleft + \Sigma M = 0; \quad M - 0.250x = 0 \quad M = \{0.250x\} \text{ kN}\cdot\text{m}$$

Ans

For $2 \text{ m} < x \leq 3 \text{ m}$ [FBD (b)],

$$+ \uparrow \Sigma F_y = 0; \quad 0.25 - 1.5(x - 2) - V = 0$$

$$V = \{3.25 - 1.50x\} \text{ kN} \quad \text{Ans}$$

$$\curvearrowleft + \Sigma M = 0; \quad 0.25x - 1.5(x - 2)\left(\frac{x - 2}{2}\right) - M = 0$$

$$M = \{-0.750x^2 + 3.25x - 3.00\} \text{ kN}\cdot\text{m} \quad \text{Ans}$$

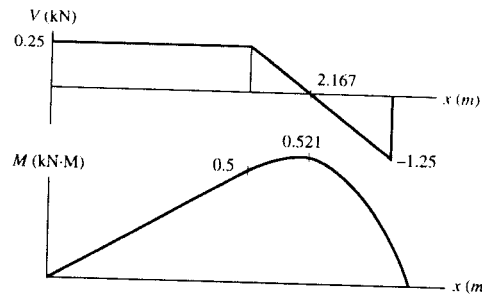
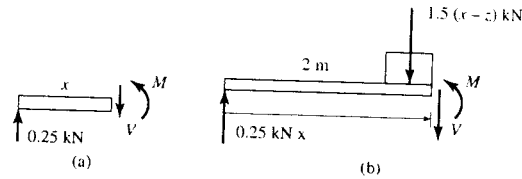
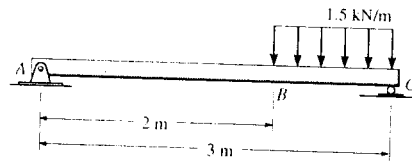

7-49. Draw the shear and bending-moment diagrams for the beam.

Support Reactions:

$$\curvearrowleft + \Sigma M_B = 0; \quad 1000(10) - 200 - A_y(20) = 0 \quad A_y = 490 \text{ lb}$$

Shear and Moment Functions: For $0 \leq x < 20 \text{ ft}$ [FBD (a)],

$$+ \uparrow \Sigma F_y = 0; \quad 490 - 50x - V = 0$$

$$V = \{490 - 50.0x\} \text{ lb} \quad \text{Ans}$$

$$\curvearrowleft + \Sigma M = 0; \quad M + 50x\left(\frac{x}{2}\right) - 490x = 0$$

$$M = \{490x - 25.0x^2\} \text{ lb}\cdot\text{ft} \quad \text{Ans}$$

For $20 \text{ ft} < x \leq 30 \text{ ft}$ [FBD (b)],

$$+ \uparrow \Sigma F_y = 0; \quad V = 0 \quad \text{Ans}$$

$$\curvearrowleft + \Sigma M = 0; \quad -200 - M = 0 \quad M = -200 \text{ lb}\cdot\text{ft} \quad \text{Ans}$$

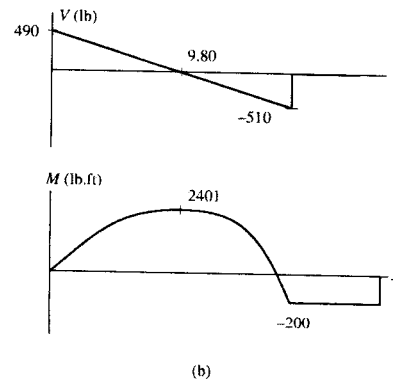
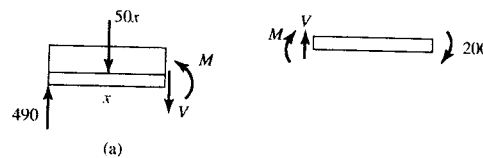
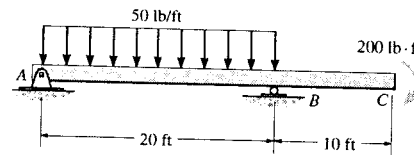

7-50. Draw the shear and moment diagrams for the beam.

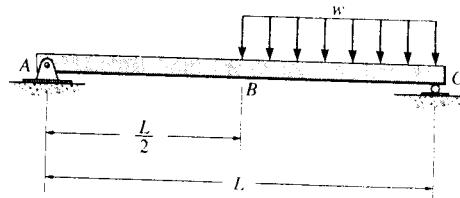

Support Reactions : From FBD (a),

$$+\uparrow \Sigma M_A = 0; \quad C_y(L) - \frac{wL}{2} \left(\frac{3L}{4} \right) = 0 \quad C_y = \frac{3wL}{8}$$

$$+\uparrow \Sigma F_y = 0; \quad A_y + \frac{3wL}{8} - \frac{wL}{2} = 0 \quad A_y = \frac{wL}{8}$$

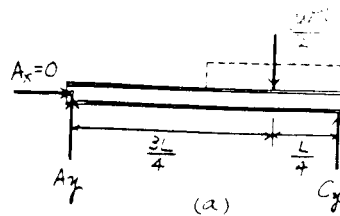

Shear and Moment Functions : For $0 \leq x < \frac{L}{2}$ [FBD (b)],

$$+\uparrow \Sigma F_y = 0; \quad \frac{wL}{8} - V = 0 \quad V = \frac{wL}{8} \quad \text{Ans}$$

$$+\circlearrowleft \Sigma M = 0; \quad M - \frac{wL}{8}(x) = 0 \quad M = \frac{wL}{8}x \quad \text{Ans}$$

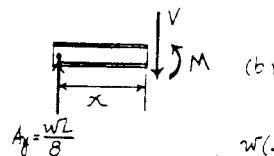

For $\frac{L}{2} < x \leq L$ [FBD (c)],

$$+\uparrow \Sigma F_y = 0; \quad V + \frac{3wL}{8} - w(L-x) = 0$$

$$V = \frac{w}{8}(5L - 8x) \quad \text{Ans}$$

$$+\circlearrowleft \Sigma M = 0; \quad \frac{3wL}{8}(L-x) - w(L-x) \left(\frac{L-x}{2} \right) - M = 0$$

$$M = \frac{w}{8}(-L^2 + 5Lx - 4x^2) \quad \text{Ans}$$

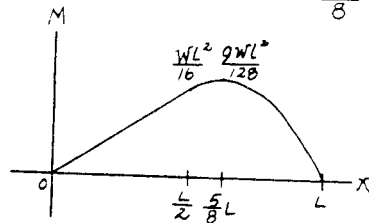
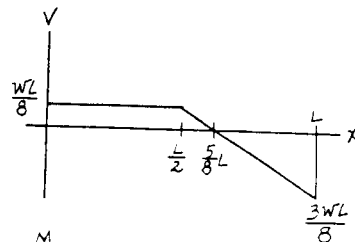
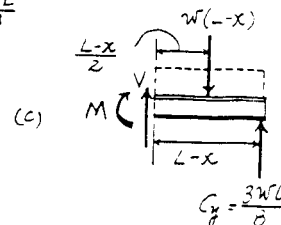

7-51. Draw the shear and moment diagrams for the beam.

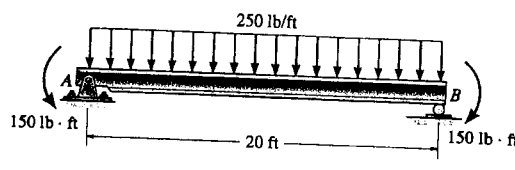

$$\begin{aligned} \sum M_A = 0; & \quad -5000(10) - 150 + B_y(20) = 0 \\ B_y = 2500 \text{ lb} \\ \sum F_x = 0; & \quad A_x = 0 \\ \sum F_y = 0; & \quad A_y - 5000 + 2500 = 0 \\ & \quad A_y = 2500 \text{ lb} \end{aligned}$$

For $0 \leq x \leq 20 \text{ ft}$

$$\begin{aligned} \sum F_y = 0; & \quad 2500 - 250x - V = 0 \\ & \quad V = 250(10 - x) \quad \text{Ans.} \\ \sum M = 0; & \quad -2500(x) + 150 + 250x\left(\frac{x}{2}\right) + M = 0 \\ & \quad M = 25(100x - 5x^2 - 6) \end{aligned}$$

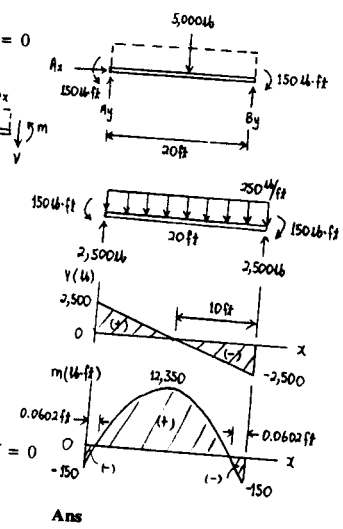

*7-52. Draw the shear and moment diagrams for the beam:

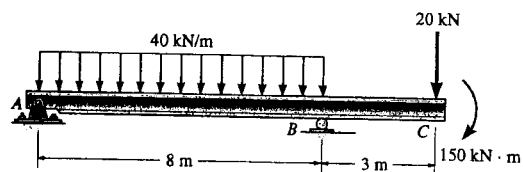

$0 \leq x < 8$

$$\begin{aligned} \sum F_y = 0; & \quad 133.75 - 40x - V = 0 \\ & \quad V = 133.75 - 40x \quad \text{Ans} \end{aligned}$$

$$\begin{aligned} \sum M = 0; & \quad M + 40x\left(\frac{x}{2}\right) - 133.75x = 0 \\ & \quad M = 133.75x - 20x^2 \quad \text{Ans} \end{aligned}$$

$8 < x \leq 11$

$$\begin{aligned} \sum F_y = 0; & \quad V - 20 = 0 \\ & \quad V = 20 \quad \text{Ans} \end{aligned}$$

$$\begin{aligned} \sum M = 0; & \quad M + 20(11 - x) + 150 = 0 \\ & \quad M = 20x - 370 \quad \text{Ans} \end{aligned}$$

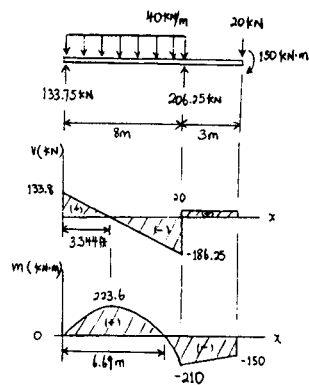

7-53. Draw the shear and bending-moment diagrams for each of the two segments of the compound beam.

Support Reactions : From FBD (a).

$$\begin{aligned} \sum M_A = 0; & B_y(12) - 2100(7) = 0 & B_y = 1225 \text{ lb} \\ + \uparrow \sum F_y = 0; & A_y + 1225 - 2100 = 0 & A_y = 875 \text{ lb} \end{aligned}$$

From FBD (b),

$$\begin{aligned} \sum M_D = 0; & 1225(6) - C_y(8) = 0 & C_y = 918.75 \text{ lb} \\ + \uparrow \sum F_y = 0; & D_y + 918.75 - 1225 = 0 & D_y = 306.25 \text{ lb} \end{aligned}$$

Shear and Moment Functions : Member AB.

For $0 \leq x < 12 \text{ ft}$ [FBD (c)].

$$\begin{aligned} + \uparrow \sum F_y = 0; & 875 - 150x - V = 0 \\ & V = \{875 - 150x\} \text{ lb} \end{aligned}$$

Ans

$$\begin{aligned} \sum M = 0; & M + 150x\left(\frac{x}{2}\right) - 875x = 0 \\ & M = \{875x - 75.0x^2\} \text{ lb} \cdot \text{ft} \end{aligned}$$

Ans

For $12 \text{ ft} < x \leq 14 \text{ ft}$ [FBD (d)].

$$\begin{aligned} + \uparrow \sum F_y = 0; & V - 150(14-x) = 0 \\ & V = \{2100 - 150x\} \text{ lb} \end{aligned}$$

Ans

$$\begin{aligned} \sum M = 0; & -150(14-x)\left(\frac{14-x}{2}\right) - M = 0 \\ & M = \{-75.0x^2 + 2100x - 14700\} \text{ lb} \cdot \text{ft} \end{aligned}$$

Ans

For member CBD, $0 \leq x < 2 \text{ ft}$ [FBD (e)].

$$+ \uparrow \sum F_y = 0; \quad 918.75 - V = 0 \quad V = 919 \text{ lb} \quad \text{Ans}$$

$$\sum M = 0; \quad 918.75x - M = 0 \quad M = \{919x\} \text{ lb} \cdot \text{ft} \quad \text{Ans}$$

For $2 \text{ ft} < x \leq 8 \text{ ft}$ [FBD (f)].

$$+ \uparrow \sum F_y = 0; \quad V + 306.25 = 0 \quad V = -306 \text{ lb} \quad \text{Ans}$$

$$\sum M = 0; \quad 306.25(8-x) - M = 0 \\ M = \{2450 - 306x\} \text{ lb} \cdot \text{ft} \quad \text{Ans}$$

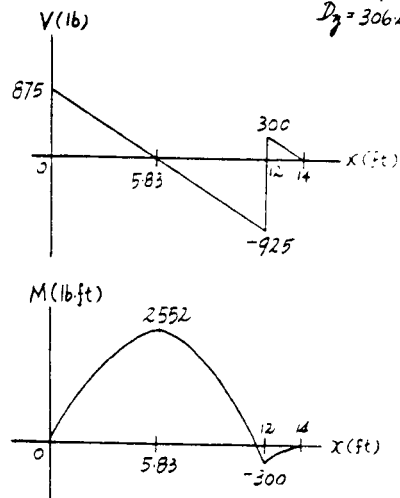
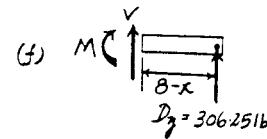
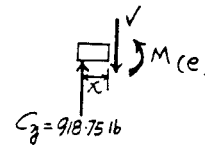
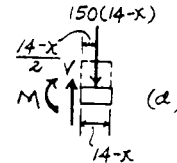
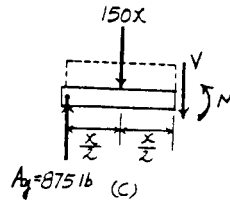
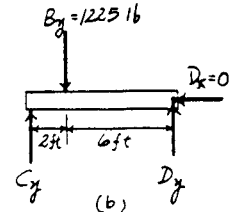
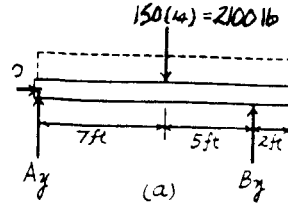
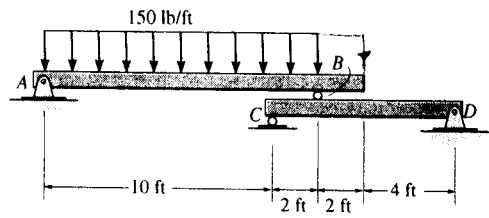
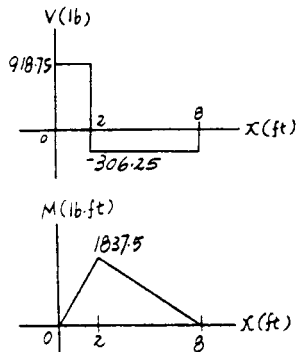

7-54. Draw the shear and bending-moment diagrams for beam ABC. Note that there is a pin at B.

Support Reactions : From FBD (a).

$$\left(+\Sigma M_C = 0; \frac{wL}{2} \left(\frac{L}{4} \right) - B_y \left(\frac{L}{2} \right) = 0 \quad B_y = \frac{wL}{4} \right.$$

From FBD (b).

$$+\uparrow \Sigma F_y = 0; \quad A_y - \frac{wL}{2} - \frac{wL}{4} = 0 \quad A_y = \frac{3wL}{4}$$

Shear and Moment Functions : For $0 \leq x \leq L$ [FBD (c)].

$$+\uparrow \Sigma F_y = 0; \quad \frac{3wL}{4} - wx - V = 0$$

$$V = \frac{w}{4} (3L - 4x)$$

Ans

$$\left(+\Sigma M = 0; \quad \frac{3wL}{4} (x) - wx \left(\frac{x}{2} \right) - \frac{wL^2}{4} - M = 0 \right.$$

$$M = \frac{w}{4} (3Lx - 2x^2 - L^2)$$

Ans

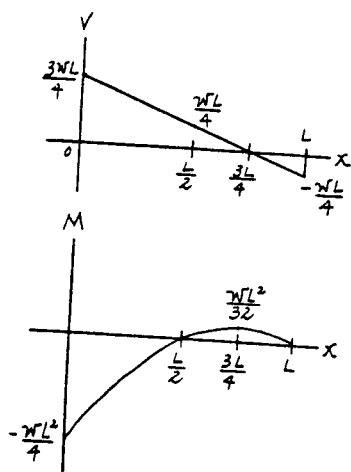
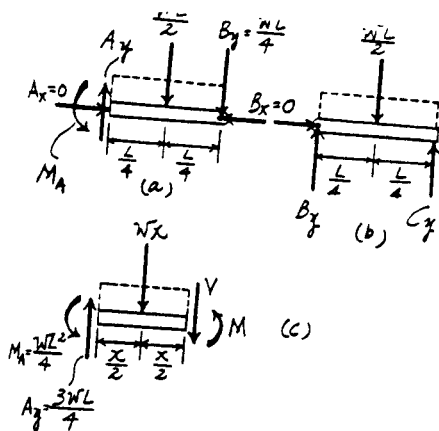
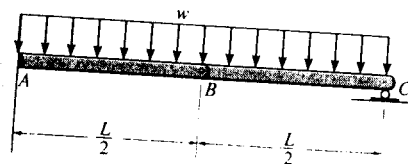

7-55. Draw the shear and moment diagrams for the compound beam. The beam is pin-connected at E and F.

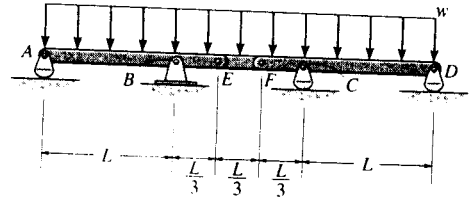

Support Reactions : From FBD (b),

$$\begin{aligned} \circlearrowleft + \Sigma M_E = 0; & \quad F_y \left(\frac{L}{3}\right) - \frac{wL}{3} \left(\frac{L}{6}\right) = 0 \quad F_y = \frac{wL}{6} \\ + \uparrow \Sigma F_y = 0; & \quad E_y + \frac{wL}{6} - \frac{wL}{3} = 0 \quad E_y = \frac{wL}{6} \end{aligned}$$

From FBD (a),

$$\circlearrowleft + \Sigma M_C = 0; \quad D_y(L) + \frac{wL}{6} \left(\frac{L}{3}\right) - \frac{4wL}{3} \left(\frac{L}{3}\right) = 0 \quad D_y = \frac{7wL}{18}$$

From FBD (c),

$$\begin{aligned} \circlearrowleft + \Sigma M_B = 0; & \quad \frac{4wL}{3} \left(\frac{L}{3}\right) - \frac{wL}{6} \left(\frac{L}{3}\right) - A_y(L) = 0 \quad A_y = \frac{7wL}{18} \\ + \uparrow \Sigma F_y = 0; & \quad B_y + \frac{7wL}{18} - \frac{4wL}{3} - \frac{wL}{6} = 0 \quad B_y = \frac{10wL}{9} \end{aligned}$$

Shear and Moment Functions : For $0 \leq x < L$ [FBD (d)],

$$\begin{aligned} + \uparrow \Sigma F_y = 0; & \quad \frac{7wL}{18} - wx - V = 0 \\ & \quad V = \frac{w}{18}(7L - 18x) \end{aligned}$$

$$\begin{aligned} \circlearrowleft + \Sigma M = 0; & \quad M + wx \left(\frac{x}{2}\right) - \frac{7wL}{18}x = 0 \\ & \quad M = \frac{w}{18}(7Lx - 9x^2) \end{aligned}$$

For $L \leq x < 2L$ [FBD (e)],

$$\begin{aligned} + \uparrow \Sigma F_y = 0; & \quad \frac{7wL}{18} + \frac{10wL}{9} - wx - V = 0 \\ & \quad V = \frac{w}{2}(3L - 2x) \end{aligned}$$

$$\begin{aligned} \circlearrowleft + \Sigma M = 0; & \quad M + wx \left(\frac{x}{2}\right) - \frac{7wL}{18}x - \frac{10wL}{9}(x-L) = 0 \\ & \quad M = \frac{w}{18}(27Lx - 20L^2 - 9x^2) \end{aligned}$$

For $2L < x \leq 3L$ [FBD (f)],

$$\begin{aligned} + \uparrow \Sigma F_y = 0; & \quad V + \frac{7wL}{18} - w(3L-x) = 0 \\ & \quad V = \frac{w}{18}(47L - 18x) \end{aligned}$$

$$\begin{aligned} \circlearrowleft + \Sigma M = 0; & \quad \frac{7wL}{18}(3L-x) - w(3L-x) \left(\frac{3L-x}{2}\right) - M = 0 \\ & \quad M = \frac{w}{18}(47Lx - 9x^2 - 60L^2) \end{aligned}$$

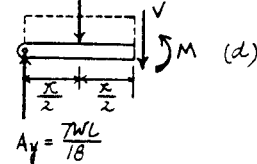
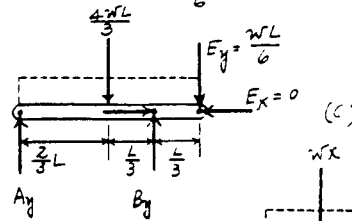
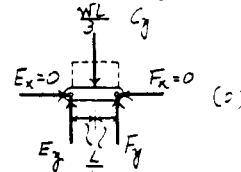
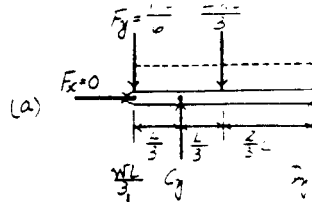

Ans

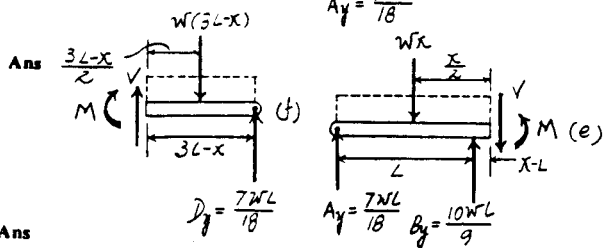

Ans

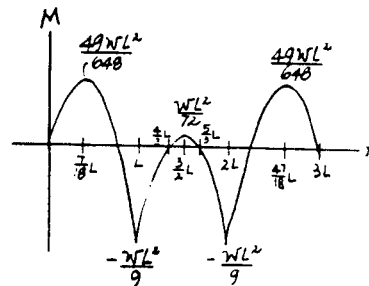
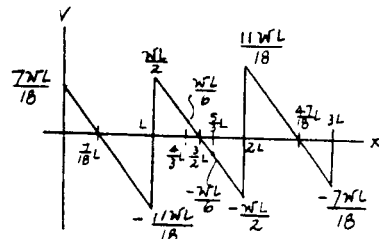

*7-56. Draw the shear and moment diagrams for the beam.

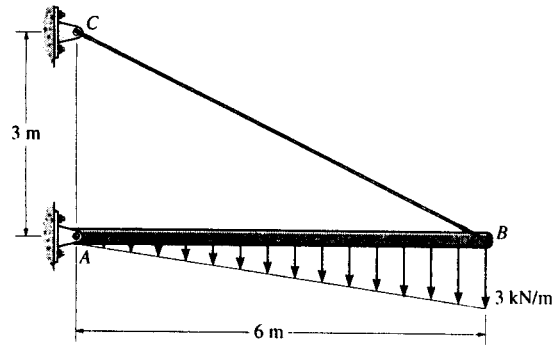

Support Reactions : From FBD (a),

$$(+\Sigma M_B = 0; \quad 9.00(2) - A_y(6) = 0 \quad A_y = 3.00 \text{ kN}$$

Shear and Moment Functions : For $0 \leq x \leq 6 \text{ m}$ [FBD (b)].

$$+\uparrow \Sigma F_y = 0; \quad 3.00 - \frac{x^2}{4} - V = 0$$

$$V = \left\{ 3.00 - \frac{x^2}{4} \right\} \text{ kN}$$

Ans

The maximum moment occurs when $V = 0$, then

$$0 = 3.00 - \frac{x^2}{4} \quad x = 3.464 \text{ m}$$

$$(+\Sigma M = 0; \quad M + \left(\frac{x^2}{4}\right)\left(\frac{x}{3}\right) - 3.00x = 0$$

$$M = \left\{ 3.00x - \frac{x^3}{12} \right\} \text{ kN} \cdot \text{m}$$

Ans

Thus,

$$M_{\max} = 3.00(3.464) - \frac{3.464^3}{12} = 6.93 \text{ kN} \cdot \text{m}$$

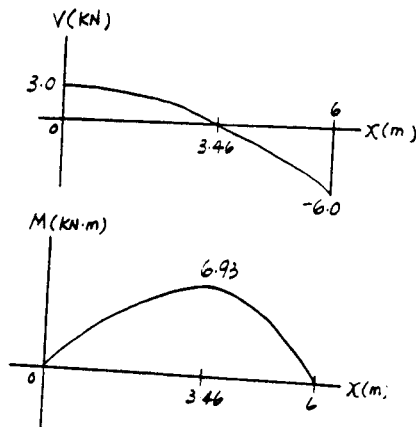
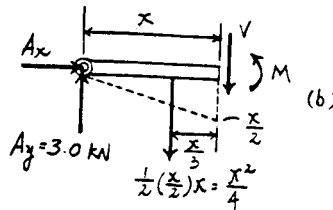
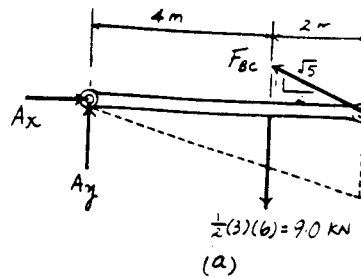

7-57. If $L = 18$ ft, the beam will fail when the maximum shear force is $V_{\max} = 800$ lb or the maximum moment is $M_{\max} = 1200$ lb-ft. Determine the largest intensity w of the distributed loading it will support.

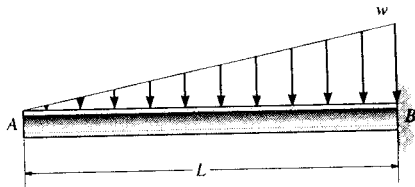

For $0 \leq x \leq L$

$$+\uparrow \Sigma F_y = 0; \quad V = -\frac{wx^2}{2L}$$

$$\curvearrowleft + \Sigma M = 0; \quad M = -\frac{wx^3}{6L}$$

$$V_{\max} = \frac{-wL}{2}$$

$$-800 = \frac{-w(18)}{2}$$

$$w = 88.9 \text{ lb/ft}$$

$$M_{\max} = -\frac{wL^2}{6}$$

$$-1200 = \frac{-w(18)^2}{6}$$

$$w = 22.2 \text{ lb/ft}$$

Ans

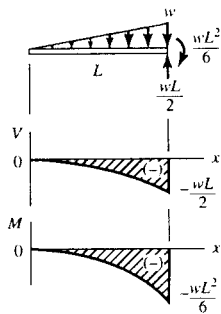
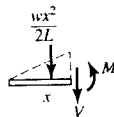

7-58. The beam will fail when the maximum internal moment is M_{max} . Determine the position x of the concentrated force P and its smallest magnitude that will cause failure.

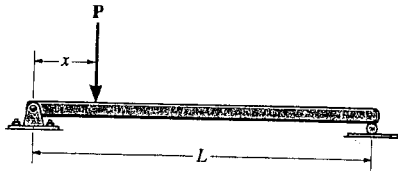

For $\xi < x$,

$$M_1 = \frac{P\xi(L-x)}{L}$$

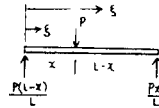

For $\xi > x$,

$$M_2 = -\frac{Px}{L}(L-\xi)$$

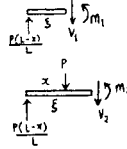

Note that $M_1 = M_2$ when $x = \xi$

$$M_{max} = M_1 = M_2 = \frac{Px}{L}(L-x)$$

$$\frac{dM_{max}}{dx} = \frac{P}{L}(L-2x) = 0$$

$$x = \frac{L}{2} \quad \text{Ans}$$

Thus, $M_{max} = \frac{P}{L} \left(\frac{L}{2}\right) \left(L - \frac{L}{2}\right) = \frac{P}{2} \left(\frac{L}{2}\right)$

$$P = \frac{4M_{max}}{L} \quad \text{Ans}$$

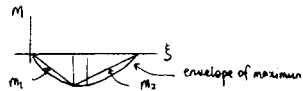

7-59. Draw the shear and moment diagrams for the beam.

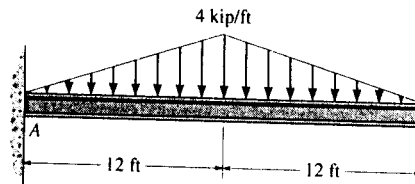

Support Reactions : From FBD (a).

$$\begin{aligned} \sum M_A = 0; & \quad M_A - 48.0(12) = 0 \quad M_A = 576 \text{ kip} \cdot \text{ft} \\ \sum F_y = 0; & \quad A_y - 48.0 = 0 \quad A_y = 48.0 \text{ kip} \end{aligned}$$

Shear and Moment Functions : For $0 \leq x < 12 \text{ ft}$ [FBD (b)].

$$+\uparrow \sum F_y = 0; \quad 48.0 - \frac{x^2}{6} - V = 0$$

$$V = \left\{ 48.0 - \frac{x^2}{6} \right\} \text{ kip}$$

Ans

$$\sum M = 0; \quad M + \frac{x^2}{6} \left(\frac{x}{3} \right) + 576 - 48.0x = 0$$

$$M = \left\{ 48.0x - \frac{x^3}{18} - 576 \right\} \text{ kip} \cdot \text{ft}$$

Ans

For $12 \text{ ft} < x \leq 24 \text{ ft}$ [FBD (c)].

$$+\uparrow \sum F_y = 0; \quad V - \frac{1}{2} \left[\frac{1}{3} (24-x) \right] (24-x) = 0$$

$$V = \left\{ \frac{1}{6} (24-x)^2 \right\} \text{ kip}$$

Ans

$$\sum M = 0; \quad -\frac{1}{2} \left[\frac{1}{3} (24-x) \right] (24-x) \left(\frac{24-x}{3} \right) - M = 0$$

$$M = \left\{ -\frac{1}{18} (24-x)^3 \right\} \text{ kip} \cdot \text{ft}$$

Ans

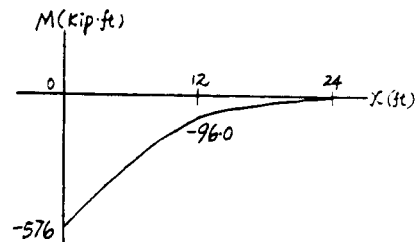
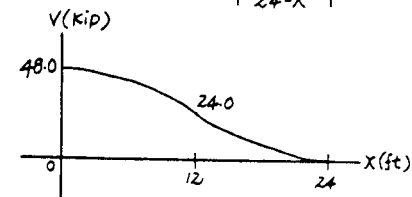
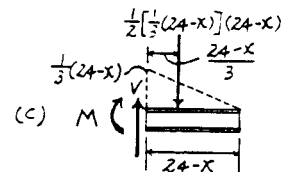
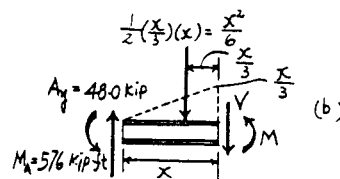
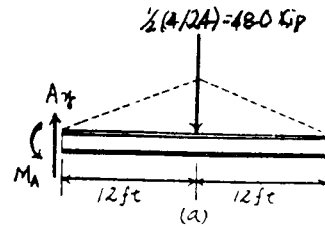

*7-60. Draw the shear and bending-moment diagrams for the beam.

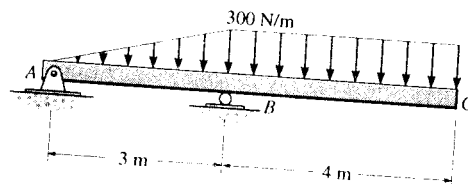

Support Reactions : From FBD (a),

$$\circlearrowleft + \Sigma M_B = 0; \quad A_y(3) + 450(1) - 1200(2) = 0 \quad A_y = 650 \text{ N}$$

Shear and Moment Functions : For $0 \leq x < 3 \text{ m}$ [FBD (b)],

$$+\uparrow \Sigma F_y = 0; \quad -650 - 50.0x^2 - V = 0$$

$$V = \{-650 - 50.0x^2\} \text{ N} \quad \text{Ans}$$

$$\circlearrowleft + \Sigma M = 0; \quad M + (50.0x^2)\left(\frac{x}{3}\right) + 650x = 0$$

$$M = \{-650x - 16.7x^3\} \text{ N}\cdot\text{m} \quad \text{Ans}$$

For $3 \text{ m} < x \leq 7 \text{ m}$ [FBD (c)],

$$+\uparrow \Sigma F_y = 0; \quad V - 300(7-x) = 0$$

$$V = \{2100 - 300x\} \text{ N} \quad \text{Ans}$$

$$\circlearrowleft + \Sigma M = 0; \quad -300(7-x)\left(\frac{7-x}{2}\right) - M = 0$$

$$M = \{-150(7-x)^2\} \text{ N}\cdot\text{m} \quad \text{Ans}$$

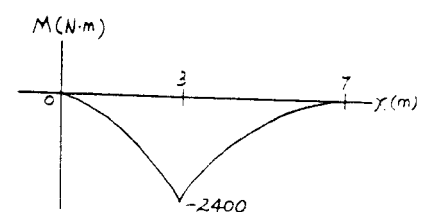
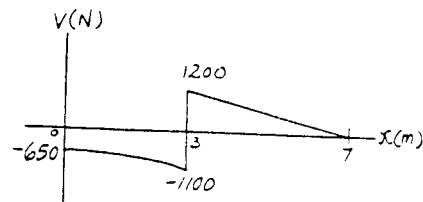
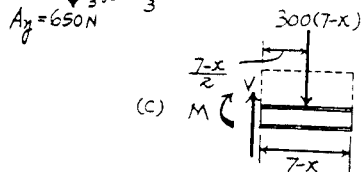
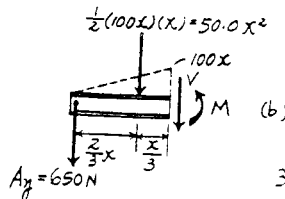
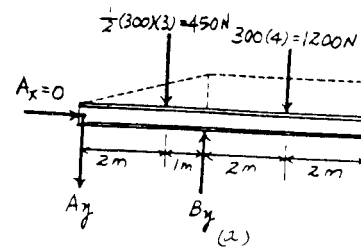

7-61. Draw the shear and moment diagrams for the beam.

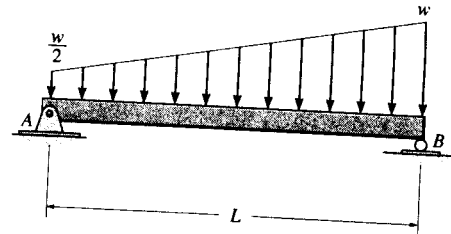

Support Reactions : From FBD (a),

$$\sum M_B = 0; \quad \frac{wL}{4} \left(\frac{L}{3} \right) + \frac{wL}{2} \left(\frac{L}{2} \right) - A_y(L) = 0 \quad A_y = \frac{wL}{3}$$

Shear and Moment Functions : For $0 \leq x \leq L$ [FBD (b)],

$$\begin{aligned} + \uparrow \sum F_y = 0; \quad \frac{wL}{3} - \frac{w}{2}x - \frac{1}{2} \left(\frac{w}{2L}x \right) x - V = 0 \\ V = \frac{w}{12L} (4L^2 - 6Lx - 3x^2) \quad \text{Ans} \end{aligned}$$

The maximum moment occurs when $V = 0$, then

$$0 = 4L^2 - 6Lx - 3x^2 \quad x = 0.5275L$$

$$\begin{aligned} \sum M = 0; \quad M + \frac{1}{2} \left(\frac{w}{2L}x \right) x \left(\frac{x}{3} \right) + \frac{wx}{2} \left(\frac{x}{2} \right) - \frac{wL}{3}(x) = 0 \\ M = \frac{w}{12L} (4L^2x - 3Lx^2 - x^3) \quad \text{Ans} \end{aligned}$$

Thus,

$$\begin{aligned} M_{\max} = \frac{w}{12L} [4L^2(0.5275L) - 3L(0.5275L)^2 - (0.5275L)^3] \\ = 0.0940wL^2 \quad \text{Ans.} \end{aligned}$$

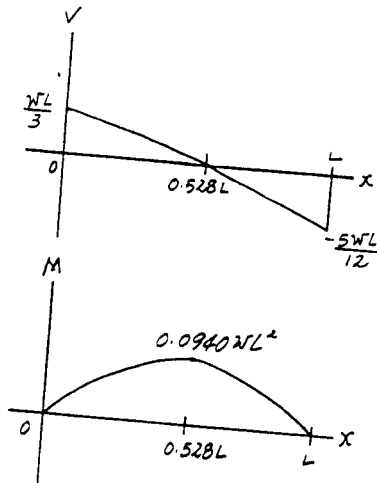
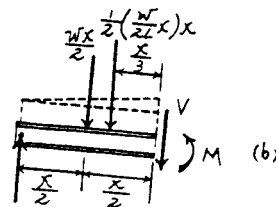
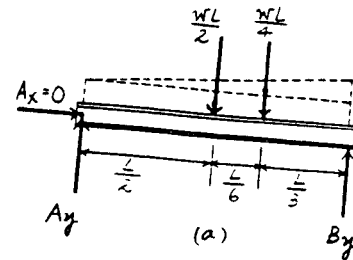

7-62. Draw the shear and moment diagrams for the beam
 (a) in terms of the parameters shown; (b) set $P = 800$ lb,
 $a = 5$ ft, $L = 12$ ft.

(a) For $0 \leq x < a$

$$+\uparrow \Sigma F_y = 0; \quad V = P$$

Ans

$$\curvearrowleft +\Sigma M = 0; \quad M = Px$$

Ans

For $a < x < L - a$

$$+\uparrow \Sigma F_y = 0; \quad V = 0$$

Ans

$$\curvearrowleft +\Sigma M = 0; \quad -Px + P(x - a) + M = 0$$

$$M = Pa$$

Ans

For $L - a < x \leq L$

$$+\uparrow \Sigma F_y = 0; \quad V = -P$$

Ans

$$\curvearrowleft +\Sigma M = 0; \quad -M + P(L - x) = 0$$

$$M = P(L - x)$$

Ans

(b) Set $P = 800$ lb, $a = 5$ ft, $L = 12$ ft

For $0 \leq x \leq 5$ ft

$$+\uparrow \Sigma F_y = 0; \quad V = 800 \text{ lb}$$

Ans

$$\curvearrowleft +\Sigma M = 0; \quad M = 800x \text{ lb}\cdot\text{ft}$$

Ans

For $5 \text{ ft} < x < 7 \text{ ft}$

$$+\uparrow \Sigma F_y = 0; \quad V = 0$$

Ans

$$\curvearrowleft +\Sigma M = 0; \quad -800x + 800(x - 5) + M = 0$$

$$M = 4000 \text{ lb}\cdot\text{ft}$$

Ans

For $7 \text{ ft} < x \leq 12 \text{ ft}$

$$+\uparrow \Sigma F_y = 0; \quad V = -800 \text{ lb}$$

Ans

$$\curvearrowleft +\Sigma M = 0; \quad -M + 800(12 - x) = 0$$

$$M = (9600 - 800x) \text{ lb}\cdot\text{ft}$$

Ans

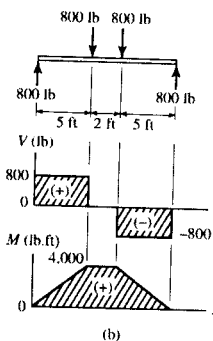
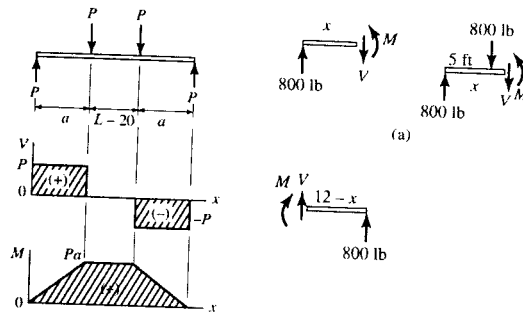
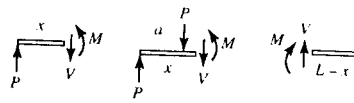
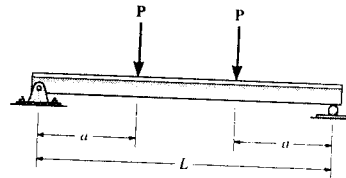

7-63. Express the x , y , z components of internal loading
 in the rod as a function of y , where $0 \leq y \leq 4$ ft.

For $0 \leq y \leq 4$ ft

$$\Sigma F_x = 0; \quad V_x = 1500 \text{ lb} = 1.5 \text{ kip} \quad \text{Ans}$$

$$\Sigma F_y = 0; \quad V_y = 0 \quad \text{Ans}$$

$$\Sigma F_z = 0; \quad V_z = 800(4 - y) \text{ lb} \quad \text{Ans}$$

$$\Sigma M_x = 0; \quad M_x - 800(4 - y) \left(\frac{4 - y}{2} \right) = 0$$

$$M_x = 400(4 - y)^2 \text{ lb}\cdot\text{ft} \quad \text{Ans}$$

$$\Sigma M_y = 0; \quad M_y + 1500(2) = 0$$

$$M_y = -3000 \text{ lb}\cdot\text{ft} = -3 \text{ kip}\cdot\text{ft} \quad \text{Ans}$$

$$\Sigma M_z = 0; \quad M_z + 1500(4 - y) = 0$$

$$M_z = -1500(4 - y) \text{ lb}\cdot\text{ft} \quad \text{Ans}$$

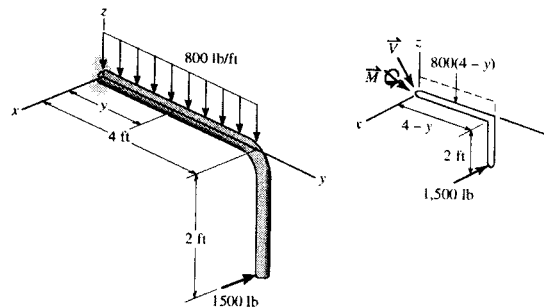

*7-64. Determine the normal force, shear force, and moment in the curved rod as a function of θ .

For $0 \leq \theta \leq 180^\circ$

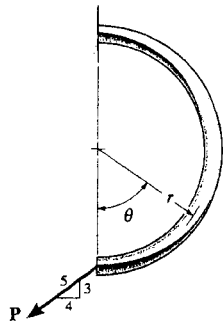

$$\sum F_x = 0; \quad N - \frac{4}{5}P \cos \theta - \frac{3}{5}P \sin \theta = 0$$

$$N = \frac{P}{5}(4 \cos \theta + 3 \sin \theta) \quad \text{Ans}$$

$$\sum F_y = 0; \quad V - \frac{4}{5}P \sin \theta + \frac{3}{5}P \cos \theta = 0$$

$$V = \frac{P}{5}(4 \sin \theta - 3 \cos \theta) \quad \text{Ans}$$

$$\sum M = 0; \quad -\frac{4}{5}P(r - r \cos \theta) + \frac{3}{5}P(r \sin \theta) + M = 0$$

$$M = \frac{Pr}{5}(4 - 4 \cos \theta - 3 \sin \theta) \quad \text{Ans}$$

Also,

$$\sum M = 0; \quad -P\left(\frac{4}{5}\right)(r) + N(r) + M = 0$$

$$M = \frac{Pr}{5}(4 - 4 \cos \theta - 3 \sin \theta) \quad \text{Ans}$$

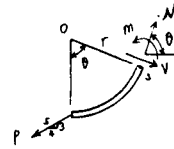

7-65. Express the internal shear and moment components acting in the rod as a function of y , where $0 \leq y \leq 4$ ft.

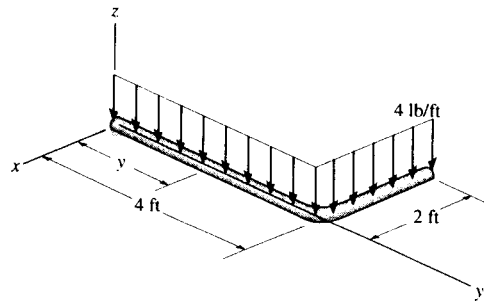

Shear and Moment Functions :

$$\Sigma F_x = 0; \quad V_x = 0$$

Ans

$$\Sigma F_z = 0; \quad V_z - 4(4-y) - 8.00 = 0$$

$$V_z = \{24.0 - 4y\} \text{ lb}$$

Ans

$$\Sigma M_x = 0; \quad M_x - 4(4-y)\left(\frac{4-y}{2}\right) - 8.00(4-y) = 0$$

$$M_x = \{2y^2 - 24y + 64.0\} \text{ lb} \cdot \text{ft}$$

Ans

$$\Sigma M_y = 0; \quad M_y - 8.00(1) = 0 \quad M_y = 8.00 \text{ lb} \cdot \text{ft}.$$

Ans

$$\Sigma M_z = 0; \quad M_z = 0$$

Ans

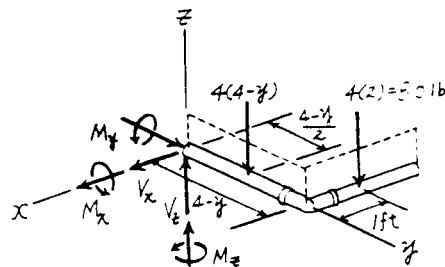

7-66. Draw the shear and moment diagrams for the beam.

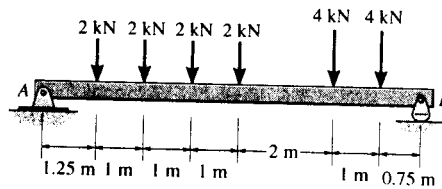

Support Reactions :

$$\begin{aligned} \sum M_A = 0: & B_y(8) - 4(7.25) - 4(6.25) - 2(4.25) \\ & \quad - 2(3.25) - 2(2.25) - 2(1.25) = 0 \\ & B_y = 9.50 \text{ kN} \\ \sum F_y = 0: & A_y + 9.50 - 2 - 2 - 2 - 2 - 4 - 4 = 0 \\ & A_y = 6.50 \text{ kN} \end{aligned}$$

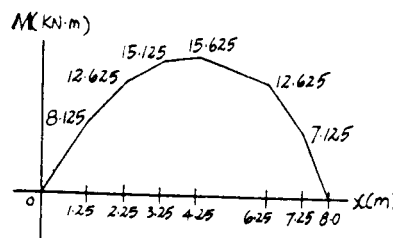
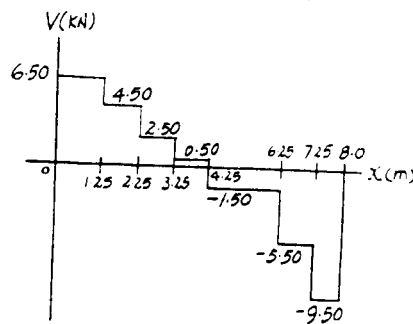
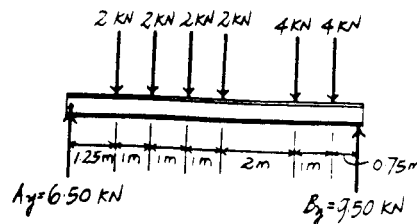

7-67. Draw the shear and moment diagrams for the beam *ABCDE*. All pulleys have a radius of 1 ft. Neglect the weight of the beam and pulley arrangement. The load weighs 500 lb.

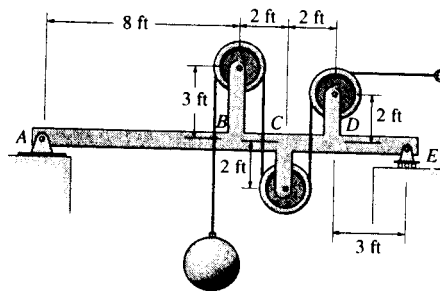

Support Reactions : From FBD (a),

$$\begin{aligned} \left(+ \Sigma M_A = 0; \quad E_y (15) - 500(7) - 500(3) = 0 \quad E_y = 333.33 \text{ lb} \right. \\ \left. + \uparrow \Sigma F_y = 0; \quad A_y + 333.33 - 500 = 0 \quad A_y = 166.67 \text{ lb} \right. \end{aligned}$$

Shear and Moment Diagrams : The load on the pulley at *D* can be replaced by equivalent force and couple moment at *D* as shown on FBD (b).

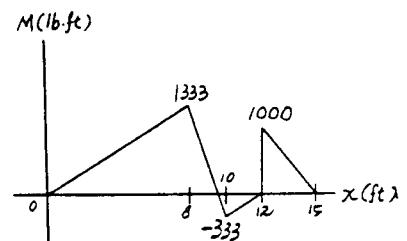
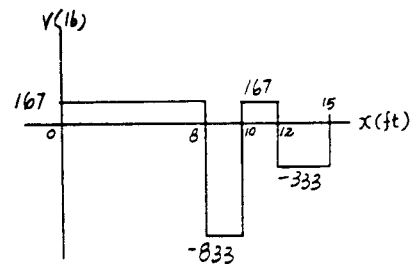
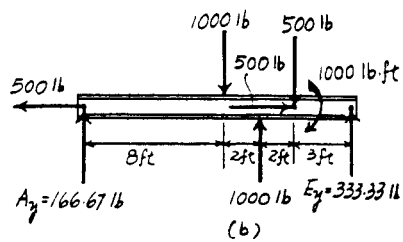
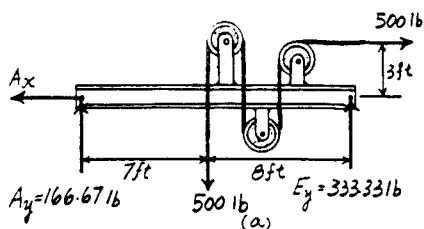

*7-68. Draw the shear and moment diagrams for the beam.

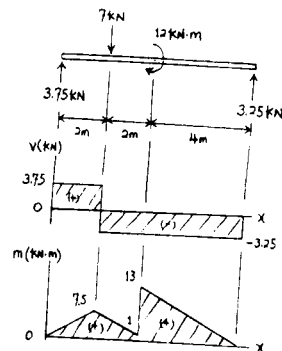
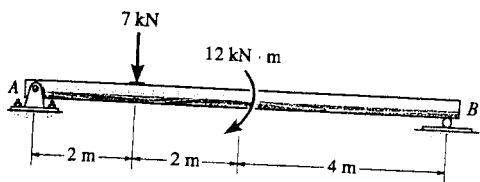

7-69. Draw the shear and moment diagrams for the beam.

Support Reactions :

$$\sum M_A = 0; \quad F_C \left(\frac{3}{5}\right)(4) - 500(2) - 500(1) = 0 \quad F_C = 625 \text{ N}$$

$$\sum F_y = 0; \quad A_y + 625 \left(\frac{3}{5}\right) - 500 - 500 = 0 \quad A_y = 625 \text{ N}$$

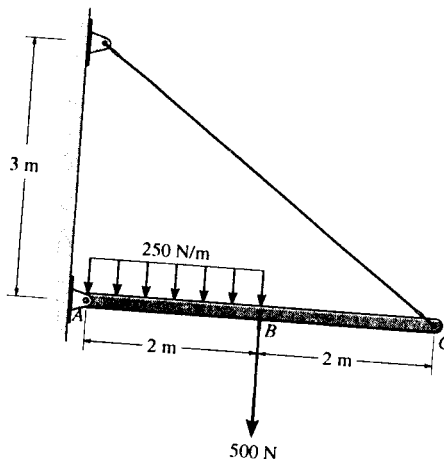
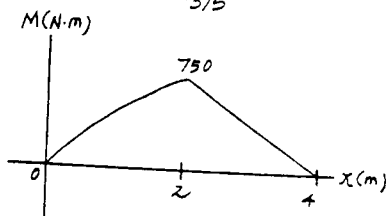
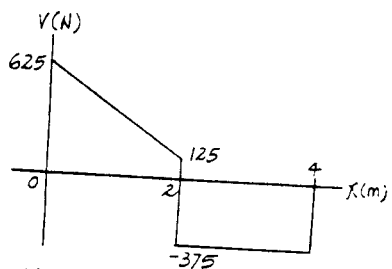
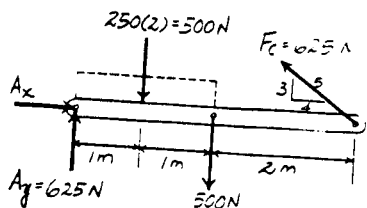

7-70. Draw the shear and moment diagrams for the beam.

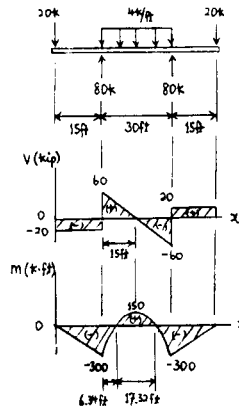
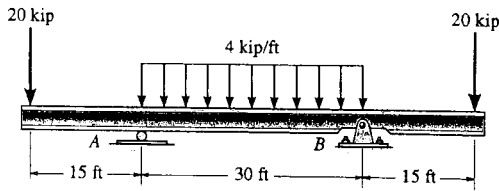

7-71. Draw the shear and moment diagrams for the beam.

Support Reactions :

$$\begin{aligned} \sum M_A = 0; & \quad B_y(8) - 320(4) - 20(11) - 150 = 0 \\ & \quad B_y = 206.25 \text{ kN} \\ \sum F_y = 0; & \quad A_y + 206.25 - 320 - 20 = 0 \quad A_y = 133.75 \text{ kN} \end{aligned}$$

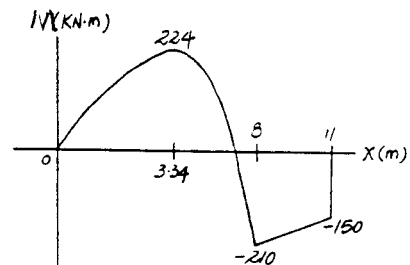
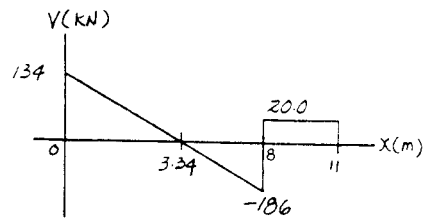
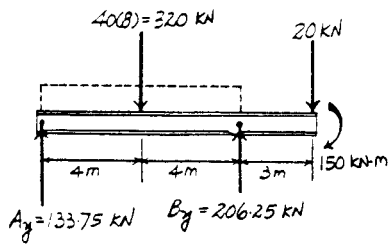
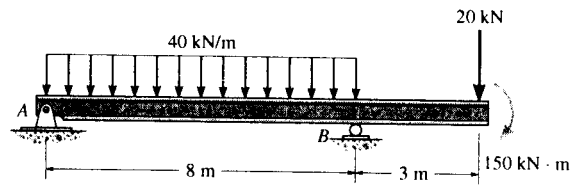

*7-72. Draw the shear and moment diagrams for the shaft. The support at A is a journal bearing and at B it is a thrust bearing.

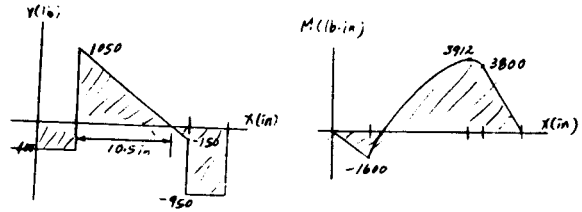
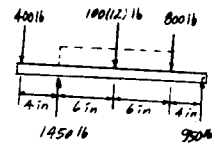
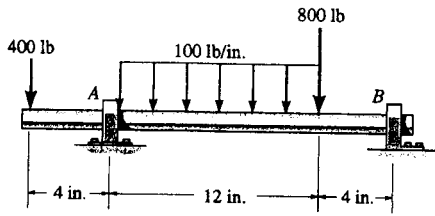

7-73. Draw the shear and moment diagrams for the beam.

Support Reactions :

$$\begin{aligned} +\Sigma M_A = 0; & B_y(10) - 10.0(2.5) - 10(8) = 0 \quad B_y = 10.5 \text{ kN} \\ +\uparrow \Sigma F_y = 0; & A_y + 10.5 - 10.0 - 10 = 0 \quad A_y = 9.50 \text{ kN} \end{aligned}$$

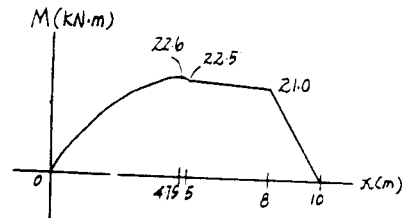
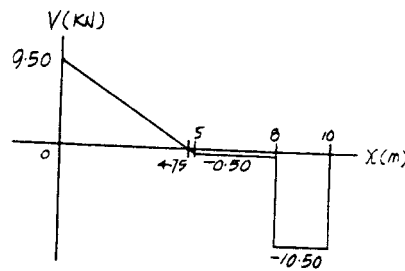
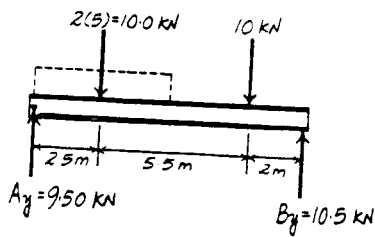
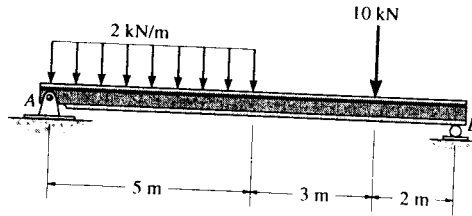

7-74. Draw the shear and moment diagrams for the shaft. The support at A is a journal bearing and at B it is a thrust bearing.

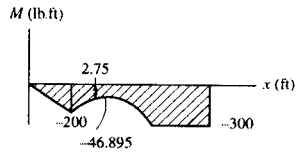
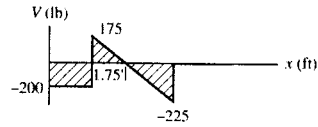
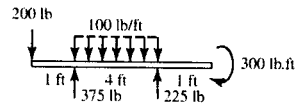
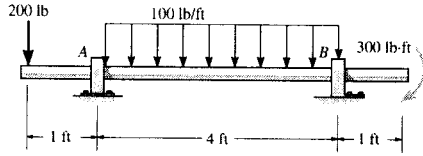

7-75. Draw the shear and moment diagrams for the beam.

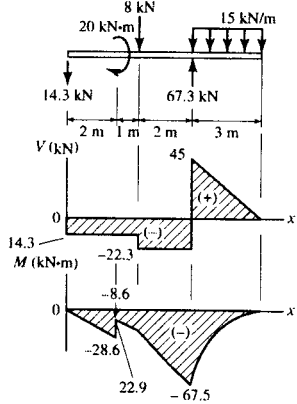
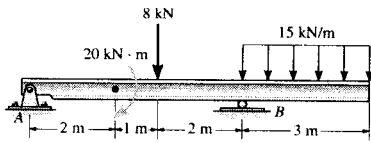

*7-76. Draw the shear and moment diagrams for the shaft. The support at A is a thrust bearing and at B it is a journal bearing.

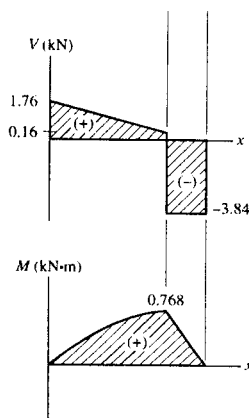
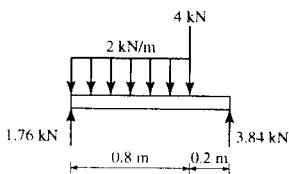
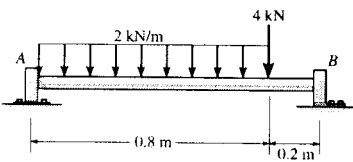

7-77. Draw the shear and moment diagrams for the beam.

Support Reactions :

$$\sum M_A = 0: D_y(3) - 8(1) - 8(2) - 15.0(3.5) - 20 = 0$$

$$D_y = 32.167 \text{ kN}$$

$$+\uparrow \sum F_y = 0: 32.167 - 8 - 8 - 15.0 - A_y = 0$$

$$A_y = 1.167 \text{ kN}$$

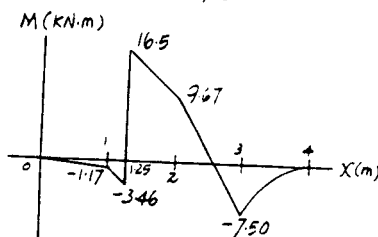
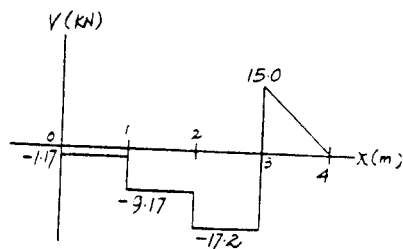
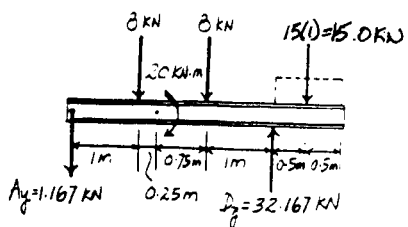
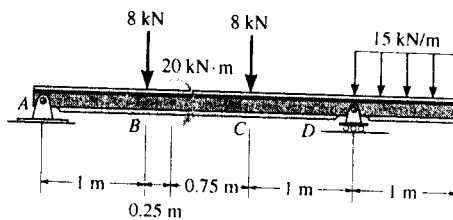

7-78. The beam will fail when the maximum moment is $M_{\max} = 30 \text{ kip} \cdot \text{ft}$ or the maximum shear is $V_{\max} = 8 \text{ kip}$. Determine the largest distributed load w the beam will support.

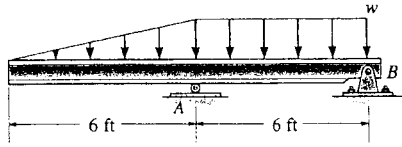

$$V_{\max} = 4w; \quad 8 = 4w$$

$$w = 2 \text{ kip/ft}$$

$$M_{\max} = -6w; \quad -30 = -6w$$

$$w = 5 \text{ kip/ft}$$

Thus, $w = 2 \text{ kip/ft}$ **Ans**

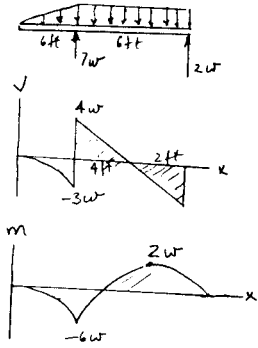

7-79. The beam consists of two segments pin connected at B. Draw the shear and moment diagrams for the beam.

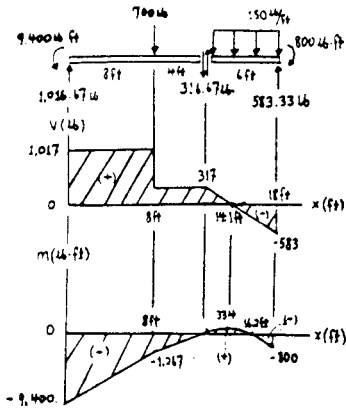
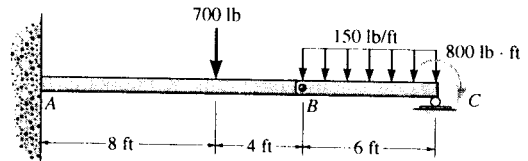

*7-80. Draw the shear and moment diagrams for the beam.

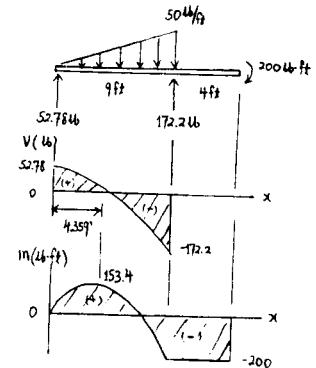
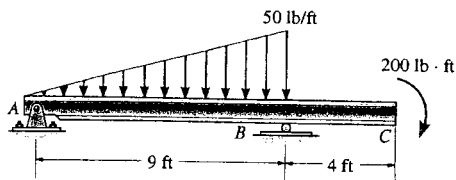

7-81. The beam consists of two segments pin-connected at B . Draw the shear and moment diagrams for the beam.

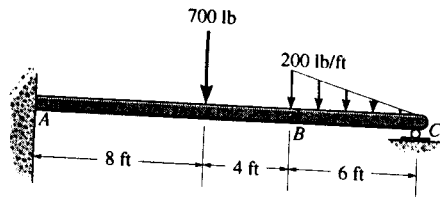

Support Reactions : From FBD (a),

$$\begin{aligned}
 +\Sigma M_B = 0; & \quad C_y(6) - 0.600(2) = 0 & \quad C_y = 0.200 \text{ kip} \\
 +\uparrow \Sigma F_y = 0; & \quad B_y + 0.200 - 0.600 = 0 & \quad B_y = 0.400 \text{ kip}
 \end{aligned}$$

From FBD (b),

$$\begin{aligned}
 (+\Sigma M_A = 0; & \quad M_A - 0.700(8) - 0.400(12) = 0 \\
 & \quad M_A = 10.4 \text{ kip}\cdot\text{ft} \\
 +\uparrow \Sigma F_y = 0; & \quad A_y - 0.700 - 0.400 = 0 & \quad A_y = 1.10 \text{ kip}
 \end{aligned}$$

Shear and Moment Diagrams : The peak value of the moment for segment BC can be evaluated using the method of sections. The maximum moment occurs when $V = 0$. From FBD (c)

$$+\uparrow \Sigma F_y = 0; \quad 0.200 - \frac{1}{2}\left(\frac{x}{30}\right)x = 0 \quad x = 2\sqrt{3} \text{ ft}$$

$$\begin{aligned}
 (+\Sigma M = 0; & \quad 0.200x - \frac{1}{2}\left(\frac{x}{30}\right)x\left(\frac{x}{3}\right) - M = 0 \\
 & \quad M = 0.200x - \frac{x^3}{180}
 \end{aligned}$$

Thus,

$$(M_{\max})_{BC} = 0.200(2\sqrt{3}) - \frac{(2\sqrt{3})^3}{180} = 0.462 \text{ kip}\cdot\text{ft}$$

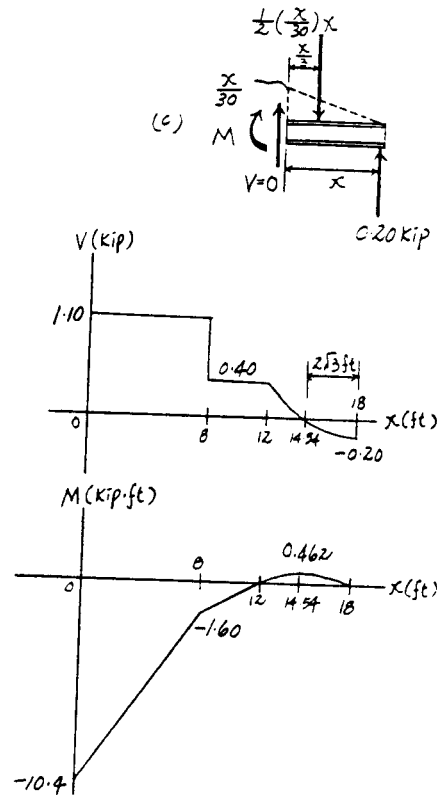
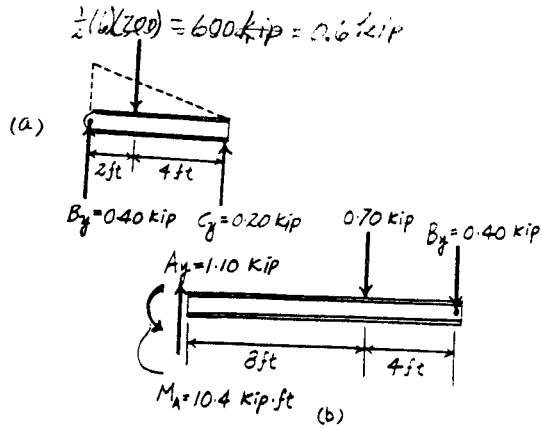

7-82. Draw the shear and moment diagrams for the beam.

Support Reactions : From FBD (a),

$$\begin{aligned} +\Sigma M_A = 0; & C_y(6) - 3.00(1) - 3.00(5) = 0 \quad C_y = 3.00 \text{ kN} \\ +\uparrow \Sigma F_y = 0; & A_y + 3.00 - 3.00 - 3.00 = 0 \quad A_y = 3.00 \text{ kN} \end{aligned}$$

Shear and Moment Diagrams : The peak value of the moment diagram can be evaluated using the method of sections. The maximum moment occurs at the midspan ($x = 3 \text{ m}$) where $V = 0$. From FBD (b),

$$+\Sigma M = 0; \quad M - 3.00(1) = 0 \quad M = 3.00 \text{ kN}\cdot\text{m}$$

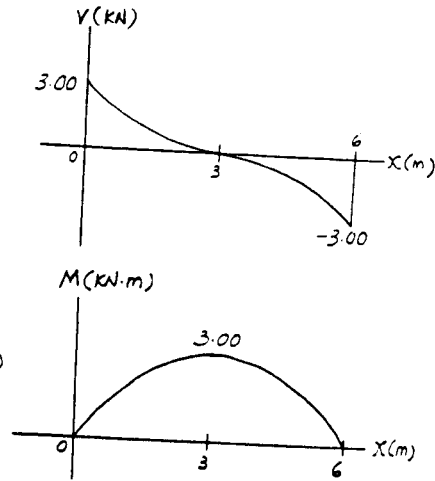
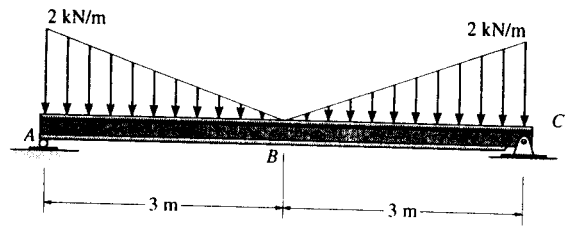
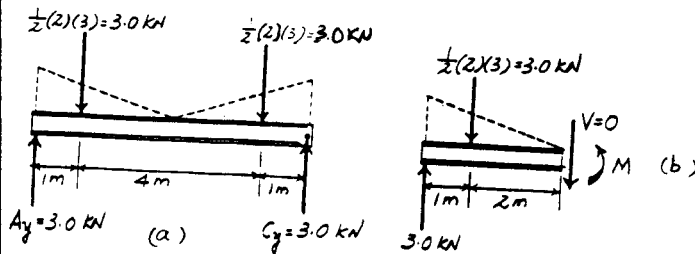

7-83. Draw the shear and moment diagrams for the beam.

Support Reactions :

$$\begin{aligned} +\Sigma M_A = 0; & B_y(L) - w_0 L \left(\frac{L}{2}\right) - \frac{w_0 L}{2} \left(\frac{4L}{3}\right) = 0 \\ & B_y = \frac{7w_0 L}{6} \\ +\uparrow \Sigma F_y = 0; & A_y + \frac{7w_0 L}{6} - w_0 L - \frac{w_0 L}{2} = 0 \\ & A_y = \frac{w_0 L}{3} \end{aligned}$$

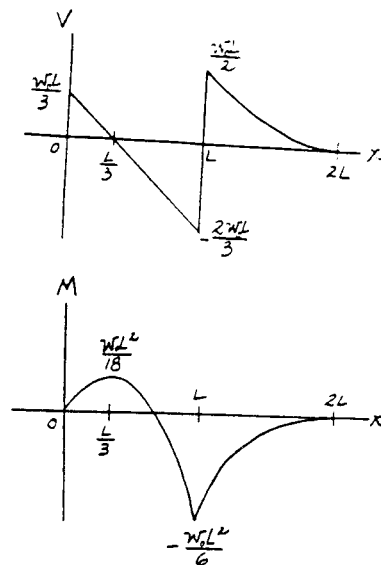
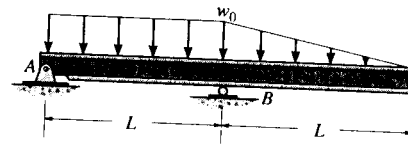
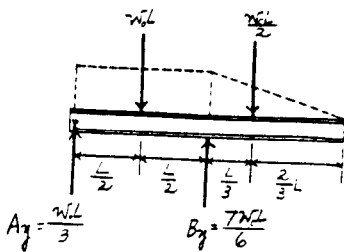

*7-84. Draw the shear and moment diagrams for the beam.

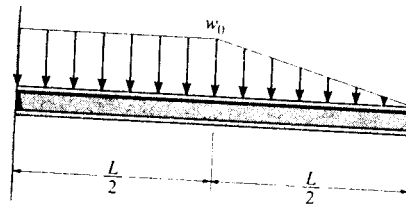

Support Reactions :

$$\begin{aligned} \sum M_A = 0; \quad M_A - \frac{w_0 L}{2} \left(\frac{L}{4} \right) - \frac{w_0 L}{4} \left(\frac{2L}{3} \right) &= 0 \\ M_A &= \frac{7w_0 L^2}{24} \end{aligned}$$

$$\sum F_y = 0; \quad A_y - \frac{w_0 L}{2} - \frac{w_0 L}{4} = 0 \quad A_y = \frac{3w_0 L}{4}$$

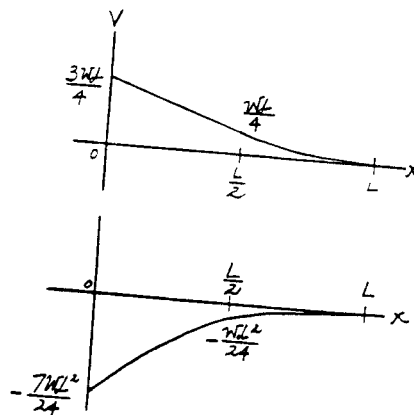
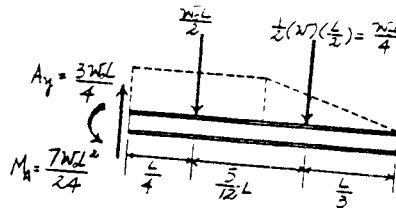

7-85. Draw the shear and moment diagrams for the beam.

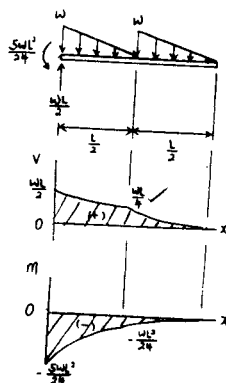
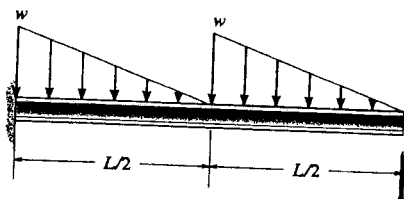

7-86. Draw the shear and moment diagrams for the beam.

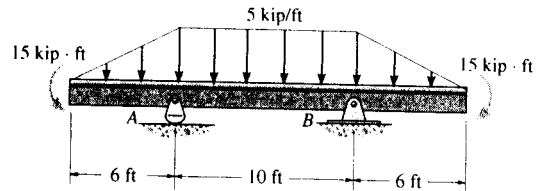

Support Reactions : From FBD (a),

$$\begin{aligned} +\Sigma M_A = 0; & \quad B_y(10) + 15.0(2) + 15 \\ & \quad - 50.0(5) - 15.0(12) - 15 = 0 \\ & \quad B_y = 40.0 \text{ kip} \\ +\Sigma F_y = 0; & \quad A_y + 40.0 - 15.0 - 50.0 - 15.0 = 0 \\ & \quad A_y = 40.0 \text{ kip} \end{aligned}$$

Shear and Moment Diagrams : The value of the moment at supports A and B can be evaluated using the method of sections [FBD (c)].

$$+\Sigma M = 0; \quad M + 15.0(2) + 15 = 0 \quad M = -45.0 \text{ kip}\cdot\text{ft}$$

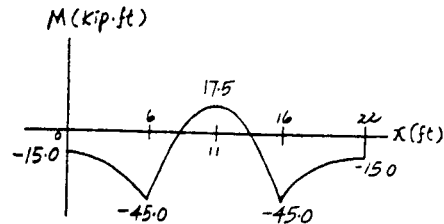
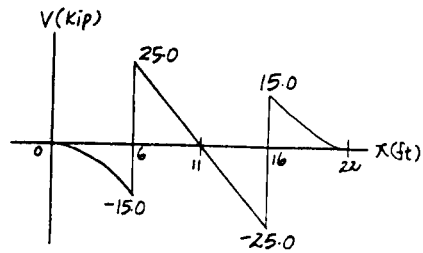
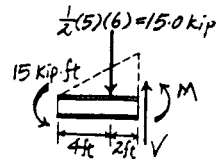
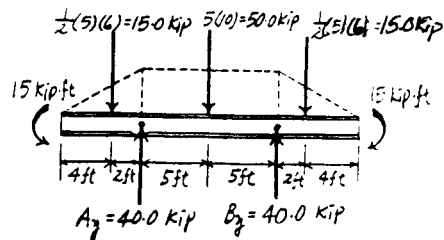

7-87. Draw the shear and moment diagrams for the beam.

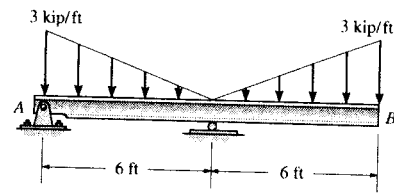

Support reactions: Shown on FBD (a)

From FBD (b)

$$+\uparrow \Sigma F_y = 0; \quad -V_6 - \frac{1}{2}(3)(6) = 0$$

$$V_6 = -9 \text{ kip}$$

$$\Sigma M = 0; \quad M_6 + \frac{1}{2}(3)(6)(4) = 0$$

$$M_6 = -36 \text{ kip}\cdot\text{ft}$$

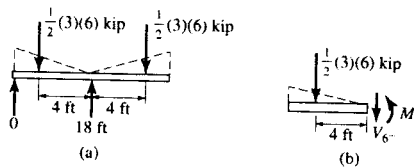
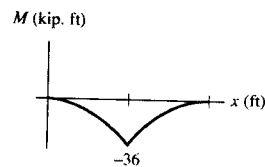
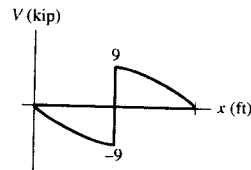

*7-88. Draw the shear and moment diagrams for the beam.

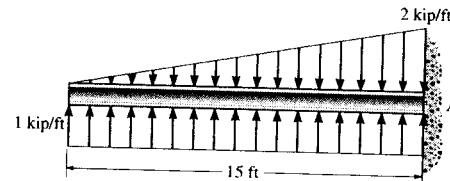

Shear and Moment Functions: For $0 \leq x < 15$ ft

$$+\uparrow \Sigma F_y = 0; \quad 1x - x^2/15 - V = 0$$

$$V = \{x - x^2/15\} \text{ N} \quad \text{Ans}$$

$$\curvearrowleft + \Sigma M = 0; \quad M + (x^2/15)\left(\frac{x}{3}\right) - 1x(x/2) = 0$$

$$M = \{x^2/2 - x^3/45\} \text{ N}\cdot\text{m} \quad \text{Ans}$$

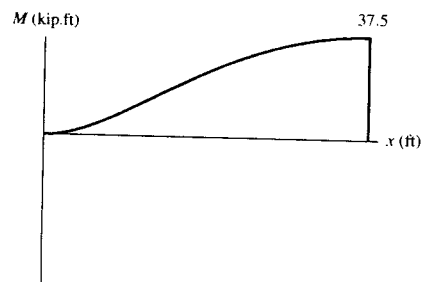
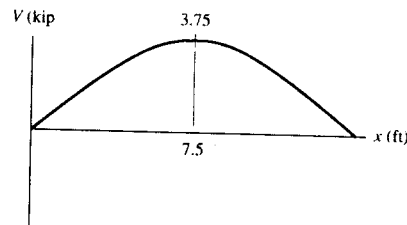

*7-89. Determine the tension in each segment of the cable and the cable's total length.

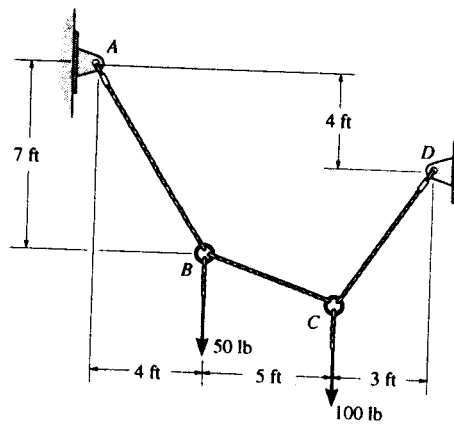

Equations of Equilibrium : Applying method of joints, we have

Joint B

$$\rightarrow \Sigma F_x = 0; \quad F_{BC} \cos \theta - F_{BA} \left(\frac{4}{\sqrt{65}} \right) = 0 \quad [1]$$

$$+ \uparrow \Sigma F_y = 0; \quad F_{BA} \left(\frac{7}{\sqrt{65}} \right) - F_{BC} \sin \theta - 50 = 0 \quad [2]$$

Joint C

$$\rightarrow \Sigma F_x = 0; \quad F_{CD} \cos \phi - F_{BC} \cos \theta = 0 \quad [3]$$

$$+ \uparrow \Sigma F_y = 0; \quad F_{BC} \sin \theta + F_{CD} \sin \phi - 100 = 0 \quad [4]$$

Geometry :

$$\sin \theta = \frac{y}{\sqrt{y^2 + 25}} \quad \cos \theta = \frac{5}{\sqrt{y^2 + 25}}$$

$$\sin \phi = \frac{3 + y}{\sqrt{y^2 + 6y + 18}} \quad \cos \phi = \frac{3}{\sqrt{y^2 + 6y + 18}}$$

Substitute the above results into Eqs. [1], [2], [3] and [4] and solve. We have

$$F_{BC} = 46.7 \text{ lb} \quad F_{BA} = 83.0 \text{ lb} \quad F_{CD} = 88.1 \text{ lb} \quad \text{Ans}$$

$$y = 2.679 \text{ ft}$$

The total length of the cable is

$$l = \sqrt{7^2 + 4^2} + \sqrt{5^2 + 2.679^2} + \sqrt{3^2 + (2.679 + 3)^2}$$

$$= 20.2 \text{ ft}$$

Ans

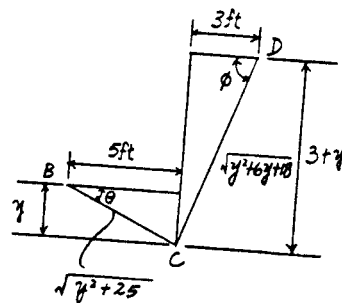
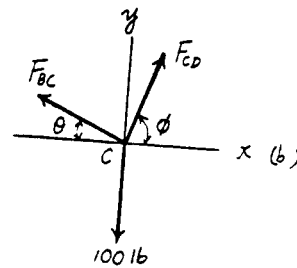
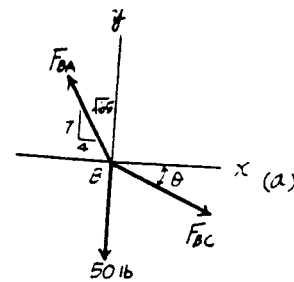

7-90. Determine the tension in each segment of the cable and the cable's total length.

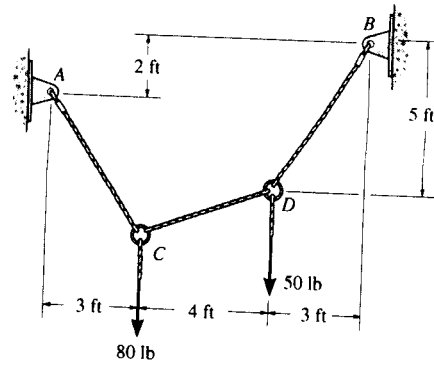

Equations of Equilibrium: Applying method of joints, we have

Joint D

$$\rightarrow \Sigma F_x = 0; \quad F_{DB} \left(\frac{3}{\sqrt{34}} \right) - F_{DC} \cos \theta = 0 \quad [1]$$

$$+ \uparrow \Sigma F_y = 0; \quad F_{DB} \left(\frac{5}{\sqrt{34}} \right) - F_{DC} \sin \theta - 50 = 0 \quad [2]$$

Joint C

$$\rightarrow \Sigma F_x = 0; \quad F_{DC} \cos \theta - F_{CA} \cos \phi = 0 \quad [3]$$

$$+ \uparrow \Sigma F_y = 0; \quad F_{DC} \sin \theta + F_{CA} \sin \phi - 80 = 0 \quad [4]$$

Geometry:

$$\sin \theta = \frac{y}{\sqrt{y^2 + 16}} \quad \cos \theta = \frac{4}{\sqrt{y^2 + 16}}$$

$$\sin \phi = \frac{y + 3}{\sqrt{y^2 + 6y + 18}} \quad \cos \phi = \frac{3}{\sqrt{y^2 + 6y + 18}}$$

Substitute the above results into Eqs. [1], [2], [3] and [4] and solve. We have

$$F_{DC} = 43.7 \text{ lb} \quad F_{DB} = 78.2 \text{ lb} \quad F_{CA} = 74.7 \text{ lb} \quad \text{Ans}$$

$$y = 1.695 \text{ ft}$$

The total length of the cable is

$$l = \sqrt{5^2 + 3^2} + \sqrt{4^2 + 1.695^2} + \sqrt{3^2 + (1.695 + 3)^2}$$

$$= 15.7 \text{ ft} \quad \text{Ans}$$

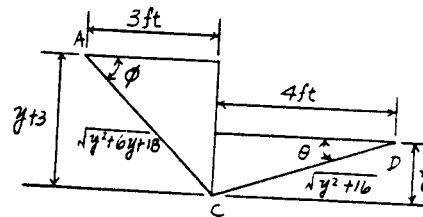
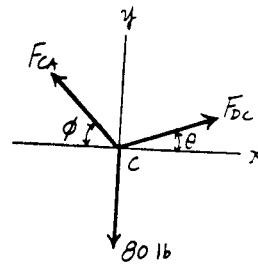
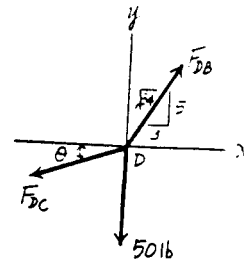

7-91. The cable supports the three loads shown. Determine the sags y_B and y_D of points B and D . Take $P_1 = 400$ lb, $P_2 = 250$ lb.

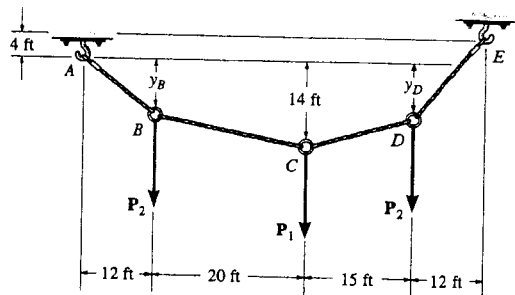

At B

$$\rightarrow \Sigma F_x = 0; \quad \frac{20}{\sqrt{(14-y_B)^2 + 400}} T_{BC} - \frac{12}{\sqrt{y_B^2 + 144}} T_{AB} = 0$$

$$+\uparrow \Sigma F_y = 0; \quad -\frac{14-y_B}{\sqrt{(14-y_B)^2 + 400}} T_{BC} + \frac{y_B}{\sqrt{y_B^2 + 144}} T_{AB} - 250 = 0$$

$$\frac{32y_B - 168}{\sqrt{(14-y_B)^2 + 400}} T_{BC} = 3000 \quad (1)$$

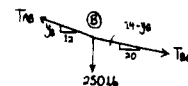

At C

$$\rightarrow \Sigma F_x = 0; \quad \frac{15}{\sqrt{(14-y_D)^2 + 225}} T_{CD} - \frac{20}{\sqrt{(14-y_B)^2 + 400}} T_{BC} = 0$$

$$+\uparrow \Sigma F_y = 0; \quad \frac{14-y_D}{\sqrt{(14-y_D)^2 + 225}} T_{CD} + \frac{14-y_B}{\sqrt{(14-y_B)^2 + 400}} T_{BC} - 400 = 0$$

$$\frac{-20y_D + 490 - 15y_B}{\sqrt{(14-y_D)^2 + 400}} T_{BC} = 6000 \quad (2)$$

$$\frac{-20y_D + 490 - 15y_B}{\sqrt{(14-y_D)^2 + 225}} T_{CD} = 8000 \quad (3)$$

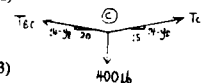

At D

$$\rightarrow \Sigma F_x = 0; \quad \frac{12}{\sqrt{(4+y_D)^2 + 144}} T_{DE} - \frac{15}{\sqrt{(14-y_D)^2 + 225}} T_{CD} = 0$$

$$+\uparrow \Sigma F_y = 0; \quad \frac{4+y_D}{\sqrt{(4+y_D)^2 + 144}} T_{DE} - \frac{14-y_D}{\sqrt{(14-y_D)^2 + 225}} T_{CD} - 250 = 0$$

$$\frac{-108 + 27y_D}{\sqrt{(14-y_D)^2 + 225}} T_{CD} = 3000 \quad (4)$$

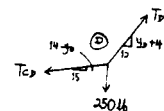

Combining Eqs. (1) & (2)

$$79y_B + 20y_D = 826$$

Combining Eqs. (3) & (4)

$$45y_B + 276y_D = 2334$$

$$y_B = 8.67 \text{ ft} \quad \text{Ans}$$

$$y_D = 7.04 \text{ ft} \quad \text{Ans}$$

*7-92. The cable supports the three loads shown. Determine the magnitude of P_1 if $P_2 = 300$ lb and $y_B = 8$ ft. Also find the sag y_D .

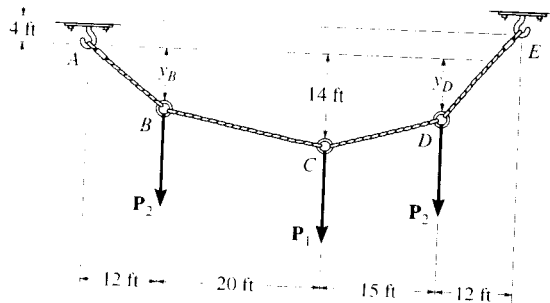

At B

$$\rightarrow \Sigma F_x = 0; \quad \frac{20}{\sqrt{436}} T_{BC} - \frac{12}{\sqrt{208}} T_{AB} = 0$$

$$+ \uparrow \Sigma F_y = 0; \quad \frac{-6}{\sqrt{436}} T_{BC} + \frac{8}{\sqrt{208}} T_{AB} - 300 = 0$$

$$T_{AB} = 983.3 \text{ lb}$$

$$T_{BC} = 854.2 \text{ lb}$$

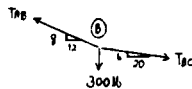

At C

$$\rightarrow \Sigma F_x = 0; \quad \frac{-20}{\sqrt{436}} (854.2) + \frac{15}{\sqrt{(14-y_D)^2 + 225}} T_{CD} = 0 \quad (1)$$

$$+ \uparrow \Sigma F_y = 0; \quad \frac{6}{\sqrt{436}} (854.2) + \frac{14-y_D}{\sqrt{(14-y_D)^2 + 225}} T_{CD} - P_1 = 0 \quad (2)$$

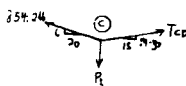

At D

$$\rightarrow \Sigma F_x = 0; \quad \frac{12}{\sqrt{(4+y_D)^2 + 144}} T_{DE} - \frac{15}{\sqrt{(14-y_D)^2 + 225}} T_{CD} = 0$$

$$+ \uparrow \Sigma F_y = 0; \quad \frac{4+y_D}{\sqrt{(4+y_D)^2 + 144}} T_{DE} - \frac{14-y_D}{\sqrt{(14-y_D)^2 + 225}} T_{CD} - 300 = 0$$

$$T_{CD} = \frac{3600\sqrt{225 + (14-y_D)^2}}{27y_D - 108}$$

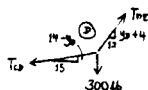

Substitute into Eq. (1):

$$y_D = 6.44 \text{ ft} \quad \text{Ans}$$

$$T_{CD} = 916.1 \text{ lb}$$

$$P_1 = 658 \text{ lb} \quad \text{Ans}$$

7-93. The cable supports the loading shown. Determine the distance x_B the force at point B acts from A. Set $P = 40$ lb.

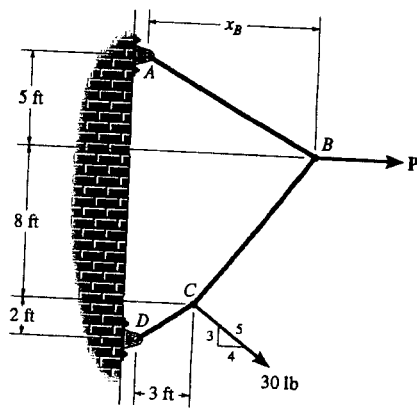

At B

$$\begin{aligned} \rightarrow \Sigma F_x = 0; & \quad 40 - \frac{x_B}{\sqrt{x_B^2 + 25}} T_{AB} - \frac{x_B - 3}{\sqrt{(x_B - 3)^2 + 64}} T_{BC} = 0 \\ + \uparrow \Sigma F_y = 0; & \quad \frac{5}{\sqrt{x_B^2 + 25}} T_{AB} - \frac{8}{\sqrt{(x_B - 3)^2 + 64}} T_{BC} = 0 \\ & \quad \frac{13x_B - 15}{\sqrt{(x_B - 3)^2 + 64}} T_{BC} = 200 \quad (1) \end{aligned}$$

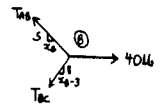

At C

$$\begin{aligned} \rightarrow \Sigma F_x = 0; & \quad \frac{4}{5}(30) + \frac{x_B - 3}{\sqrt{(x_B - 3)^2 + 64}} T_{BC} - \frac{3}{\sqrt{13}} T_{CD} = 0 \\ + \uparrow \Sigma F_y = 0; & \quad \frac{8}{\sqrt{(x_B - 3)^2 + 64}} T_{BC} - \frac{2}{\sqrt{13}} T_{CD} - \frac{3}{5}(30) = 0 \\ & \quad \frac{30 - 2x_B}{\sqrt{(x_B - 3)^2 + 64}} T_{BC} = 102 \quad (2) \end{aligned}$$

Solving Eqs. (1) & (2)

$$\begin{aligned} \frac{13x_B - 15}{30 - 2x_B} &= \frac{200}{102} \\ x_B &= 4.36 \text{ ft} \quad \text{Ans} \end{aligned}$$

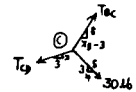

7-94. The cable supports the loading shown. Determine the magnitude of the horizontal force P so that $x_B = 6$ ft.

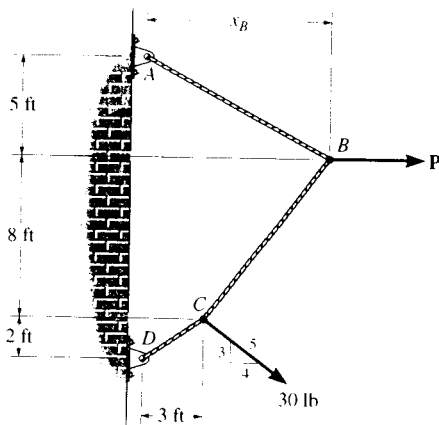

At B

$$\begin{aligned} \rightarrow \Sigma F_x = 0; & \quad P - \frac{6}{\sqrt{61}} T_{AB} - \frac{3}{\sqrt{73}} T_{BC} = 0 \\ + \uparrow \Sigma F_y = 0; & \quad \frac{5}{\sqrt{61}} T_{AB} - \frac{8}{\sqrt{73}} T_{BC} = 0 \\ & \quad 5P - \frac{63}{\sqrt{73}} T_{BC} = 0 \quad (1) \end{aligned}$$

At C

$$\begin{aligned} \rightarrow \Sigma F_x = 0; & \quad \frac{4}{5}(30) + \frac{3}{\sqrt{73}} T_{BC} - \frac{3}{\sqrt{13}} T_{CD} = 0 \\ + \uparrow \Sigma F_y = 0; & \quad \frac{8}{\sqrt{73}} T_{BC} - \frac{2}{\sqrt{13}} T_{CD} - \frac{3}{5}(30) = 0 \\ & \quad \frac{18}{\sqrt{73}} T_{BC} = 102 \quad (2) \end{aligned}$$

Solving Eqs. (1) & (2)

$$\begin{aligned} \frac{63}{18} &= \frac{5P}{102} \\ P &= 71.4 \text{ lb} \quad \text{Ans} \end{aligned}$$

7-95. Determine the forces P_1 and P_2 needed to hold the cable in the position shown, i.e., so segment CD remains horizontal. Also, find the maximum tension in the cable.

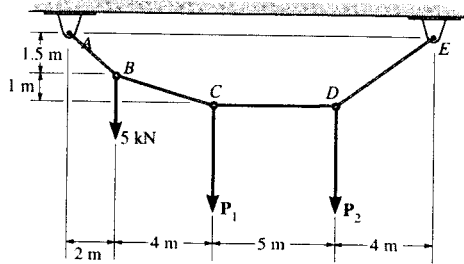

Method of Joints:

Joint B

$$\rightarrow \Sigma F_x = 0; \quad F_{BC} \left(\frac{4}{\sqrt{17}} \right) - F_{AB} \left(\frac{2}{2.5} \right) = 0 \quad [1]$$

$$+ \uparrow \Sigma F_y = 0; \quad F_{AB} \left(\frac{1.5}{2.5} \right) - F_{BC} \left(\frac{1}{\sqrt{17}} \right) - 5 = 0 \quad [2]$$

Solving Eqs. [1] and [2] yields

$$F_{BC} = 10.31 \text{ kN} \quad F_{AB} = 12.5 \text{ kN}$$

Joint C

$$\rightarrow \Sigma F_x = 0; \quad F_{CD} - 10.31 \left(\frac{4}{\sqrt{17}} \right) = 0 \quad F_{CD} = 10.0 \text{ kN}$$

$$+ \uparrow \Sigma F_y = 0; \quad 10.31 \left(\frac{1}{\sqrt{17}} \right) - P_1 = 0 \quad P_1 = 2.50 \text{ kN} \quad \text{Ans}$$

Joint D

$$\rightarrow \Sigma F_x = 0; \quad F_{DE} \left(\frac{4}{\sqrt{22.25}} \right) - 10 = 0 \quad [1]$$

$$+ \uparrow \Sigma F_y = 0; \quad F_{DE} \left(\frac{P_2}{\sqrt{22.25}} \right) - 2.5 = 0 \quad [2]$$

Solving Eqs. [1] and [2] yields

$$P_2 = 6.25 \text{ kN} \quad \text{Ans}$$

$$F_{DE} = 11.79 \text{ kN}$$

Thus, the maximum tension in the cable is

$$F_{\max} = F_{AB} = 12.5 \text{ kN} \quad \text{Ans}$$

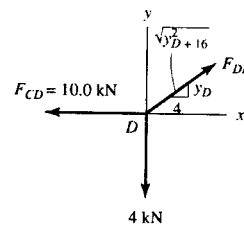
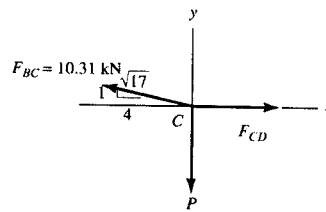
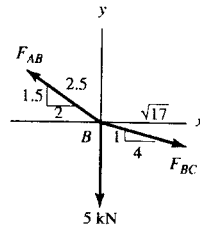

*7-96. The cable supports the three loads shown. Determine the sags y_B and y_D of points B and D and the tension in each segment of the cable.

Equations of Equilibrium: From FBD (a),

$$\begin{aligned} \left(+\Sigma M_E = 0; \right. & -F_{AB} \left(\frac{y_B}{\sqrt{y_B^2 + 144}} \right) (47) - F_{AB} \left(\frac{12}{\sqrt{y_B^2 + 144}} \right) (y_B + 4) \\ & + 200(12) + 500(27) + 300(47) = 0 \\ & F_{AB} \left(\frac{47y_B}{\sqrt{y_B^2 + 144}} \right) + F_{AB} \left(\frac{12(y_B + 4)}{\sqrt{y_B^2 + 144}} \right) = 30000 \end{aligned} \quad [1]$$

From FBD (b),

$$\begin{aligned} \left(+\Sigma M_C = 0; \right. & -F_{AB} \left(\frac{y_B}{\sqrt{y_B^2 + 144}} \right) (20) + F_{AB} \left(\frac{12}{\sqrt{y_B^2 + 144}} \right) (14 - y_B) \\ & + 300(20) = 0 \\ & F_{AB} \left(\frac{20y_B}{\sqrt{y_B^2 + 144}} \right) - F_{AB} \left(\frac{12(14 - y_B)}{\sqrt{y_B^2 + 144}} \right) = 6000 \end{aligned} \quad [2]$$

Solving Eqs. [1] and [2] yields

$$y_B = 8.792 \text{ ft} = 8.79 \text{ ft} \quad F_{AB} = 787.47 \text{ lb} = 787 \text{ lb} \quad \text{Ans}$$

Method of Joints:

Joint B

$$\begin{aligned} \rightarrow \Sigma F_x = 0; & F_{BC} \cos 14.60^\circ - 787.47 \cos 36.23^\circ = 0 \\ & F_{BC} = 656.40 \text{ lb} = 656 \text{ lb} \quad \text{Ans} \end{aligned}$$

$$\begin{aligned} + \uparrow \Sigma F_y = 0; & 787.47 \sin 36.23^\circ \\ & - 656.40 \sin 14.60^\circ - 300 = 0 \quad (\text{Checks!}) \end{aligned}$$

Joint C

$$\begin{aligned} \rightarrow \Sigma F_x = 0; & F_{CD} \left(\frac{15}{\sqrt{y_D^2 - 28y_D + 421}} \right) - 656.40 \cos 14.60^\circ = 0 \end{aligned} \quad [3]$$

$$\begin{aligned} + \uparrow \Sigma F_y = 0; & F_{CD} \left(\frac{14 - y_D}{\sqrt{y_D^2 - 28y_D + 421}} \right) \\ & + 656.40 \sin 14.60^\circ - 500 = 0 \end{aligned} \quad [4]$$

Solving Eqs. [1] and [2] yields

$$y_D = 6.099 \text{ ft} = 6.10 \text{ ft} \quad F_{CD} = 717.95 \text{ lb} = 718 \text{ lb} \quad \text{Ans}$$

Joint D

$$\begin{aligned} \rightarrow \Sigma F_x = 0; & F_{DE} \cos 40.08^\circ - 717.95 \cos 27.78^\circ = 0 \\ & F_{DE} = 830.24 \text{ lb} = 830 \text{ lb} \quad \text{Ans} \end{aligned}$$

$$\begin{aligned} + \uparrow \Sigma F_y = 0; & 830.24 \sin 40.08^\circ \\ & - 717.95 \sin 27.78^\circ - 200 = 0 \quad (\text{Checks!}) \end{aligned}$$

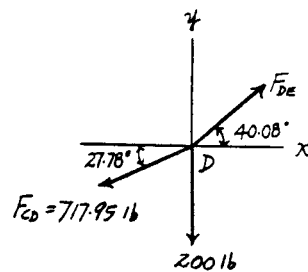
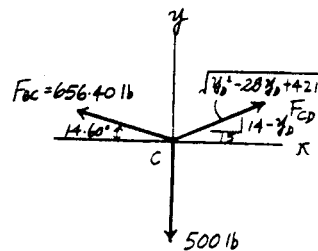
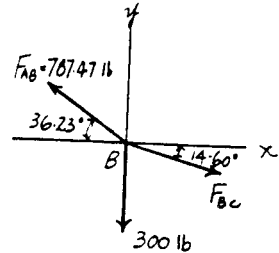
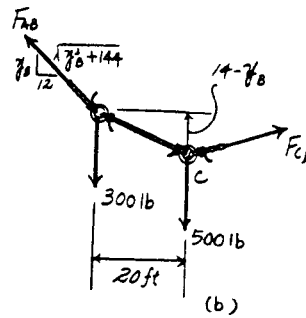
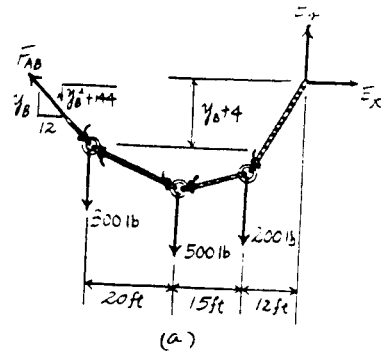
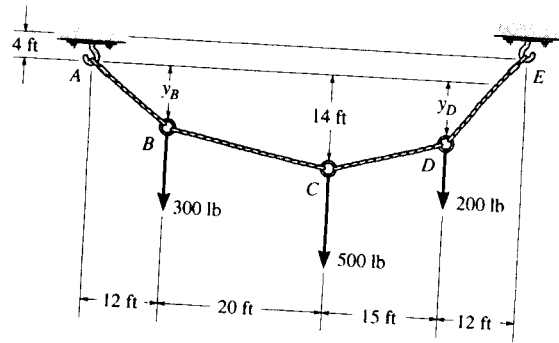

7-97. Determine the maximum uniform loading w , measured in lb/ft, that the cable can support if it is capable of sustaining a maximum tension of 3000 lb before it will break.

$$y = \frac{1}{F_H} \int \left(\int w dx \right) dx$$

$$\text{At } x = 0, \quad \frac{dy}{dx} = 0$$

$$\text{At } x = 0, \quad y = 0$$

$$C_1 = C_2 = 0$$

$$y = \frac{w}{2F_H} x^2$$

$$\text{At } x = 25 \text{ ft}, \quad y = 6 \text{ ft} \quad F_H = 52.08 w$$

$$\left. \frac{dy}{dx} \right|_{x=25} = \tan \theta_{\max} = \left. \frac{w}{F_H} x \right|_{x=25}$$

$$\theta_{\max} = \tan^{-1}(0.48) = 25.64^\circ$$

$$T_{\max} = \frac{F_H}{\cos \theta_{\max}} = 3000$$

$$F_H = 2705 \text{ lb}$$

$$w = 51.9 \text{ lb/ft} \quad \text{Ans}$$

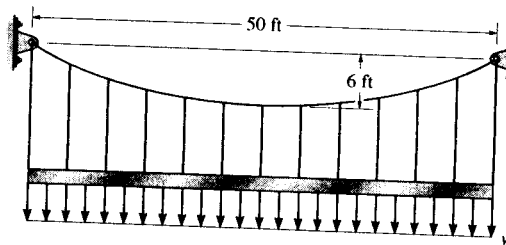
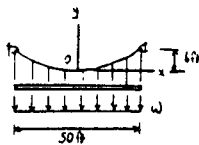

7-98. The cable is subjected to a uniform loading of $w = 250$ lb/ft. Determine the maximum and minimum tension in the cable.

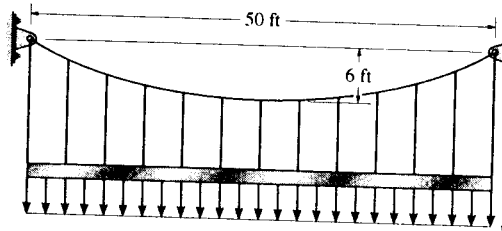

From Example 7-14;

$$F_H = \frac{w_0 L^2}{8h} = \frac{250(50)^2}{8(6)} = 13\,021 \text{ lb}$$

$$\theta_{\max} = \tan^{-1} \left(\frac{w_0 L}{2F_H} \right) = \tan^{-1} \left(\frac{250(50)}{2(13\,021)} \right) = 25.64^\circ$$

$$T_{\max} = \frac{F_H}{\cos \theta_{\max}} = \frac{13\,021}{\cos 25.64^\circ} = 14.4 \text{ kip} \quad \text{Ans}$$

The minimum tension occurs at $\theta = 0^\circ$.

$$T_{\min} = F_H = 13.0 \text{ kip} \quad \text{Ans}$$

7-99. The cable AB is subjected to a uniform loading of 200 N/m . If the weight of the cable is neglected and the slope angles at points A and B are 30° and 60° , respectively, determine the curve that defines the cable shape and the maximum tension developed in the cable.

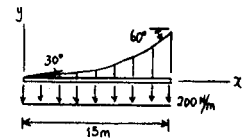
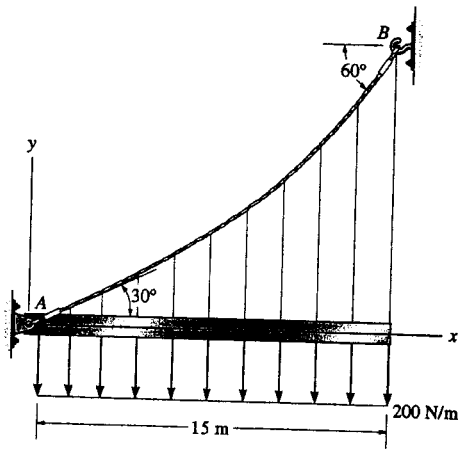

$$y = \frac{1}{F_H} \int (\int 200 \, dx) \, dx$$

$$y = \frac{1}{F_H} (100x^2 + C_1x + C_2)$$

$$\frac{dy}{dx} = \frac{1}{F_H} (200x + C_1)$$

$$\text{At } x = 0, \quad y = 0; \quad C_2 = 0$$

$$\text{At } x = 0, \quad \frac{dy}{dx} = \tan 30^\circ; \quad C_1 = F_H \tan 30^\circ$$

$$y = \frac{1}{F_H} (100x^2 + F_H \tan 30^\circ x)$$

$$\text{At } x = 15 \text{ m}, \quad \frac{dy}{dx} = \tan 60^\circ; \quad F_H = 2598 \text{ N}$$

$$y = (38.5x^2 + 577x)(10^{-3}) \text{ m} \quad \text{Ans}$$

$$\theta_{max} = 60^\circ$$

$$T_{max} = \frac{F_H}{\cos \theta_{max}} = \frac{2598}{\cos 60^\circ} = 5196 \text{ N}$$

$$T_{max} = 5.20 \text{ kN} \quad \text{Ans}$$

*7-100. The cable supports a girder which weighs 850 lb/ft. Determine the tension in the cable at points A, B, and C.

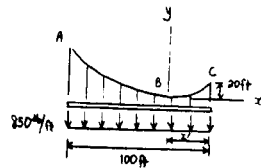
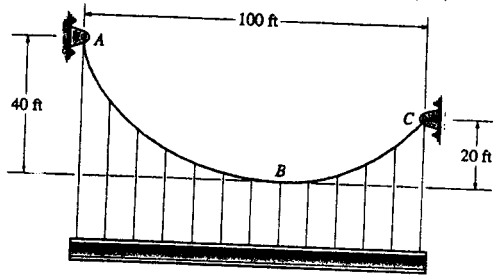

$$y = \frac{1}{F_H} \int (\int w_0 dx) dx$$

$$y = \frac{1}{F_H} (425x^2 + C_1x + C_2)$$

$$\frac{dy}{dx} = \frac{850}{F_H}x + \frac{C_1}{F_H}$$

$$\text{At } x = 0, \quad \frac{dy}{dx} = 0 \quad C_1 = 0$$

$$\text{At } x = 0, \quad y = 0 \quad C_2 = 0$$

$$y = \frac{425}{F_H}x^2$$

$$\text{At } y = 20 \text{ ft}, \quad x = x'$$

$$20 = \frac{425(x')^2}{F_H}$$

$$\text{At } y = 40 \text{ ft}, \quad x = (100 - x')$$

$$40 = \frac{425(100 - x')^2}{F_H}$$

$$2(x')^2 = (x')^2 - 200x' + 100^2$$

$$(x')^2 + 200x' - 100^2 = 0$$

$$x' = \frac{-200 \pm \sqrt{200^2 + 4(100)^2}}{2} = 41.42 \text{ ft}$$

$$F_H = 36\,459 \text{ lb}$$

At A,

$$\frac{dy}{dx} = \tan \theta_A = \left. \frac{2(425)x}{F_H} \right|_{x=38.58 \text{ ft}} = 1.366$$

$$\theta_A = 53.79^\circ$$

$$T_A = \frac{F_H}{\cos \theta_A} = \frac{36\,459}{\cos 53.79^\circ} = 61\,714 \text{ lb}$$

$$T_A = 61.7 \text{ kip} \quad \text{Ans}$$

At B,

$$T_B = F_H = 36.5 \text{ kip} \quad \text{Ans}$$

At C,

$$\frac{dy}{dx} = \tan \theta_C = \left. \frac{2(425)x}{F_H} \right|_{x=41.42 \text{ ft}} = 0.9657$$

$$\theta_C = 44.0^\circ$$

$$T_C = \frac{F_H}{\cos \theta_C} = \frac{36\,459}{\cos 44.0^\circ} = 50\,683 \text{ lb}$$

$$T_C = 50.7 \text{ kip} \quad \text{Ans}$$

7-10L. The cable is subjected to the triangular loading. If the slope of the cable at point O is zero, determine the equation of the curve $y = f(x)$ which defines the cable shape OB , and the maximum tension developed in the cable.

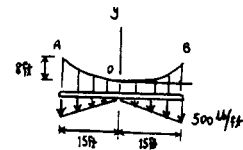
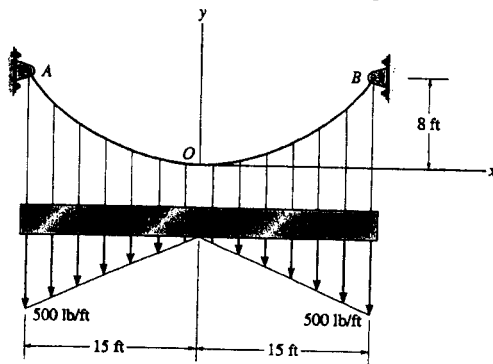

$$\begin{aligned}
 y &= \frac{1}{F_H} \int (\int w(x) dx) dx \\
 &= \frac{1}{F_H} \int (\int \frac{500}{15} x dx) dx \\
 &= \frac{1}{F_H} \int (\frac{50}{3} x^2 + C_1) dx \\
 &= \frac{1}{F_H} (\frac{50}{9} x^3 + C_1 x + C_2)
 \end{aligned}$$

$$\frac{dy}{dx} = \frac{50}{3F_H} x^2 + \frac{C_1}{F_H}$$

$$\text{At } x = 0, \quad \frac{dy}{dx} = 0 \quad C_1 = 0$$

$$\text{At } x = 0, \quad y = 0 \quad C_2 = 0$$

$$y = \frac{50}{9F_H} x^3$$

$$\text{At } x = 15 \text{ ft}, \quad y = 8 \text{ ft} \quad F_H = 2344 \text{ lb}$$

$$y = 2.37(10^{-3})x^3 \quad \text{Ans}$$

$$\left. \frac{dy}{dx} \right|_{x=15 \text{ ft}} = \tan \theta_{\max} = \left. \frac{50}{3(2344)} x^2 \right|_{x=15 \text{ ft}}$$

$$\theta_{\max} = \tan^{-1}(1.6) = 57.99^\circ$$

$$T_{\max} = \frac{F_H}{\cos \theta_{\max}} = \frac{2344}{\cos 57.99^\circ} = 4422 \text{ lb}$$

$$T_{\max} = 4.42 \text{ kip} \quad \text{Ans}$$

7-102. The cable is subjected to the parabolic loading $w = 150(1 - (x/50)^2)$ lb/ft, where x is in ft. Determine the equation $y = f(x)$ which defines the cable shape AB and the maximum tension in the cable.

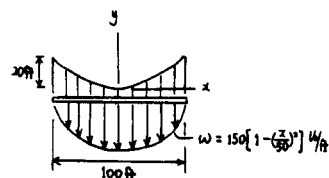
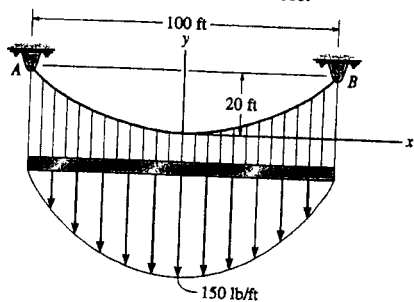

$$y = \frac{1}{F_H} \int (\int w(x) dx) dx$$

$$y = \frac{1}{F_H} \int [150x - \frac{x^3}{3(50)^2}] + C_1 dx$$

$$y = \frac{1}{F_H} (75x^2 - \frac{x^4}{200} + C_1x + C_2)$$

$$\frac{dy}{dx} = \frac{150x}{F_H} - \frac{1}{50F_H} x^3 + \frac{C_1}{F_H}$$

At $x = 0$, $\frac{dy}{dx} = 0$ $C_1 = 0$

At $x = 0$, $y = 0$ $C_2 = 0$

$$y = \frac{1}{F_H} (75x^2 - \frac{x^4}{200})$$

At $x = 50$ ft, $y = 20$ ft $F_H = 7813$ lb

$$y = \frac{x^2}{7813} (75 - \frac{x^2}{200}) \text{ ft} \quad \text{Ans}$$

$$\frac{dy}{dx} = \frac{1}{7813} (150x - \frac{4x^3}{200}) \Big|_{x=50 \text{ ft}} = \tan \theta_{max}$$

$$\theta_{max} = 32.62^\circ$$

$$T_{max} = \frac{F_H}{\cos \theta_{max}} = \frac{7813}{\cos 32.62^\circ} = 9275.9 \text{ lb}$$

$$T_{max} = 9.28 \text{ kip} \quad \text{Ans}$$

7-103. The cable will break when the maximum tension reaches $T_{\max} = 10\text{ kN}$. Determine the sag h if it supports the uniform distributed load of $w = 600\text{ N/m}$.

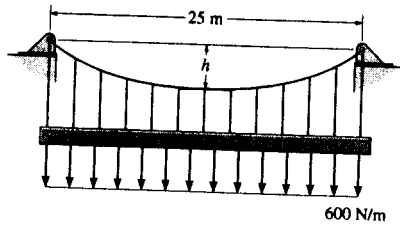

The Equation of The Cable :

$$y = \frac{1}{F_H} \int (\int w(x) dx) dx$$

$$= \frac{1}{F_H} \left(\frac{w_0}{2} x^2 + C_1 x + C_2 \right) \quad [1]$$

$$\frac{dy}{dx} = \frac{1}{F_H} (w_0 x + C_1) \quad [2]$$

Boundary Conditions :

$$y = 0 \text{ at } x = 0, \text{ then from Eq.[1]} \quad 0 = \frac{1}{F_H} (C_2) \quad C_2 = 0$$

$$\frac{dy}{dx} = 0 \text{ at } x = 0, \text{ then from Eq.[2]} \quad 0 = \frac{1}{F_H} (C_1) \quad C_1 = 0$$

$$\text{Thus,} \quad y = \frac{w_0}{2F_H} x^2 \quad [3]$$

$$\frac{dy}{dx} = \frac{w_0}{F_H} x \quad [4]$$

$$y = h \text{ at } x = 12.5 \text{ m, then from Eq.[3]} \quad h = \frac{w_0}{2F_H} (12.5^2) \quad F_H = \frac{78.125}{h} w_0$$

$\theta = \theta_{\max}$ at $x = 12.5$ m and the maximum tension occurs when $\theta = \theta_{\max}$. From Eq.[4]

$$\tan \theta_{\max} = \left. \frac{dy}{dx} \right|_{x=12.5 \text{ m}} = \frac{w_0}{F_H} x = \frac{78.125}{h} w_0 x = 0.0128h(12.5) = 0.160h$$

$$\text{Thus,} \quad \cos \theta_{\max} = \frac{1}{\sqrt{0.0256h^2 + 1}}$$

The maximum tension in the cable is

$$T_{\max} = \frac{F_H}{\cos \theta_{\max}}$$

$$10 = \frac{\frac{78.125}{h} (0.6)}{\frac{1}{\sqrt{0.0256h^2 + 1}}}$$

$$h = 7.09 \text{ m} \quad \text{Ans}$$

*7-104. Determine the maximum tension developed in the cable if it is subjected to a uniform load of 600 N/m.

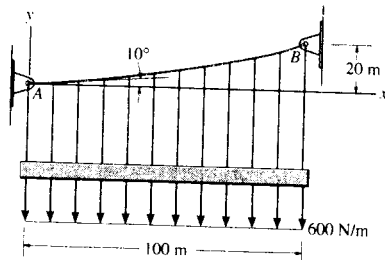

The Equation of The Cable :

$$y = \frac{1}{F_H} \int (\int w(x) dx) dx$$

$$= \frac{1}{F_H} \left(\frac{w_0}{2} x^2 + C_1 x + C_2 \right) \quad [1]$$

$$\frac{dy}{dx} = \frac{1}{F_H} (w_0 x + C_1) \quad [2]$$

Boundary Conditions :

$$y = 0 \text{ at } x = 0, \text{ then from Eq.[1]} \quad 0 = \frac{1}{F_H} (C_2) \quad C_2 = 0$$

$$\frac{dy}{dx} = \tan 10^\circ \text{ at } x = 0, \text{ then from Eq.[2]} \quad \tan 10^\circ = \frac{1}{F_H} (C_1) \quad C_1 = F_H \tan 10^\circ$$

$$\text{Thus,} \quad y = \frac{w_0}{2F_H} x^2 + \tan 10^\circ x \quad [3]$$

$y = 20 \text{ m}$ at $x = 100 \text{ m}$, then from Eq.[3]

$$20 = \frac{600}{2F_H} (100^2) + \tan 10^\circ (100) \quad F_H = 1\,267\,265.47 \text{ N}$$

and

$$\frac{dy}{dx} = \frac{w_0}{F_H} x + \tan 10^\circ$$

$$= \frac{600}{1\,267\,265.47} x + \tan 10^\circ$$

$$= 0.4735 (10^{-3}) x + \tan 10^\circ$$

$\theta = \theta_{\max}$ at $x = 100 \text{ m}$ and the maximum tension occurs when $\theta = \theta_{\max}$.

$$\tan \theta_{\max} = \left. \frac{dy}{dx} \right|_{x=100 \text{ m}} = 0.4735 (10^{-3}) (100) + \tan 10^\circ$$

$$\theta_{\max} = 12.61^\circ$$

The maximum tension in the cable is

$$T_{\max} = \frac{F_H}{\cos \theta_{\max}} = \frac{1\,267\,265.47}{\cos 12.61^\circ} = 1\,298\,579.00 \text{ N} = 1.30 \text{ MN} \quad \text{Ans}$$

■ 7-105. A cable has a weight of 5 lb/ft. If it can span 300 ft and has a sag of 15 ft, determine the length of the cable. The ends of the cable are supported at the same elevation.

$$w_0 = 5 \text{ lb/ft}$$

From Example 7-15,

$$y = \frac{F_H}{w_0} \left[\cosh \left(\frac{w_0}{F_H} x \right) - 1 \right]$$

$$\text{At } x = 150 \text{ ft, } y = 15 \text{ ft}$$

$$\frac{15w_0}{F_H} = \cosh \left(\frac{150w_0}{F_H} \right) - 1$$

$$F_H = 3762 \text{ lb}$$

$$s = \frac{F_H}{w_0} \sinh \left(\frac{w_0}{F_H} x \right)$$

$$s = 151.0 \text{ ft}$$

$$L = 2s = 302 \text{ ft} \quad \text{Ans}$$

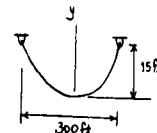

7-106. Show that the deflection curve of the cable discussed in Example 7-15 reduces to Eq. (4) in Example 7-14 when the *hyperbolic cosine function* is expanded in terms of a series and only the first two terms are retained. (The answer indicates that the *catenary* may be replaced by a *parabola* in the analysis of problems in which the sag is small. In this case, the cable weight is assumed to be uniformly distributed along the horizontal.)

$$\cosh x = 1 + \frac{x^2}{2!} + \dots$$

Substituting into

$$\begin{aligned} y &= \frac{F_H}{w_0} \left[\cosh \left(\frac{w_0}{F_H} x \right) - 1 \right] \\ &= \frac{F_H}{w_0} \left[1 + \frac{w_0^2 x^2}{2F_H^2} + \dots - 1 \right] \\ &\cong \frac{w_0 x^2}{2F_H} \end{aligned}$$

Using Eq. (3) in Example 7-14,

$$F_H = \frac{w_0 L^2}{8h}$$

$$\text{We get } y = \frac{4h}{L^2} x^2 \quad \text{QED}$$

7-107. A uniform cord is suspended between two points having the same elevation. Determine the sag-to-span ratio so that the maximum tension in the cord equals the cord's total weight.

From Example 7-15.

$$s = \frac{F_H}{w_0} \sinh\left(\frac{w_0 x}{F_H}\right)$$

$$y = \frac{F_H}{w_0} \left[\cosh\left(\frac{w_0 x}{F_H}\right) - 1 \right]$$

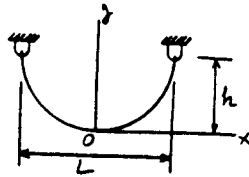

$$\tanh\left(\frac{w_0 L}{2F_H}\right) = \frac{1}{2}$$

$$\frac{w_0 L}{2F_H} = \tanh^{-1}(0.5) = 0.5493$$

At $x = \frac{L}{2}$,

when $x = \frac{L}{2}$, $y = h$

$$\left. \frac{dy}{dx} \right|_{\max} = \tan \theta_{\max} = \sinh\left(\frac{w_0 L}{2F_H}\right)$$

$$h = \frac{F_H}{w_0} \left[\cosh\left(\frac{w_0 x}{F_H}\right) - 1 \right]$$

$$\cos \theta_{\max} = \frac{1}{\cosh\left(\frac{w_0 L}{2F_H}\right)}$$



$$h = \frac{F_H}{w_0} \left\{ \frac{1}{\sqrt{1 - \tanh^2\left(\frac{w_0 L}{2F_H}\right)}} - 1 \right\} = 0.1547 \left(\frac{F_H}{w_0} \right)$$

$$T_{\max} = \frac{F_H}{\cos \theta_{\max}}$$

$$\frac{0.1547 L}{2h} = 0.5493$$

$$w_0(2s) = F_H \cosh\left(\frac{w_0 L}{2F_H}\right)$$

$$\frac{h}{L} = 0.141 \quad \text{Ans}$$

$$2F_H \sinh\left(\frac{w_0 L}{2F_H}\right) = F_H \cosh\left(\frac{w_0 L}{2F_H}\right)$$

*7-108. A cable has a weight of 2 lb/ft. If it can span 100 ft and has a sag of 12 ft, determine the length of the cable. The ends of the cable are supported from the same elevation.

From Eq. (5) of Example 7-15:

$$h = \frac{F_H}{w_0} \left[\cosh\left(\frac{w_0 L}{2F_H}\right) - 1 \right]$$

$$12 = \frac{F_H}{2} \left[\cosh\left(\frac{2(100)}{2F_H}\right) - 1 \right]$$

$$24 = F_H \left[\cosh\left(\frac{100}{F_H}\right) - 1 \right]$$

$$F_H = 212.2 \text{ lb}$$

From Eq. (3) of Example 7-15:

$$s = \frac{F_H}{w_0} \sinh\left(\frac{w_0}{F_H} x\right)$$

$$\frac{l}{2} = \frac{212.2}{2} \sinh\left(\frac{2(50)}{212.2}\right)$$

$$l = 104 \text{ ft} \quad \text{Ans}$$

7-109. The transmission cable having a weight of 20 lb/ft is strung across the river as shown. Determine the required force that must be applied to the cable at its points of attachment to the towers at *B* and *C*.

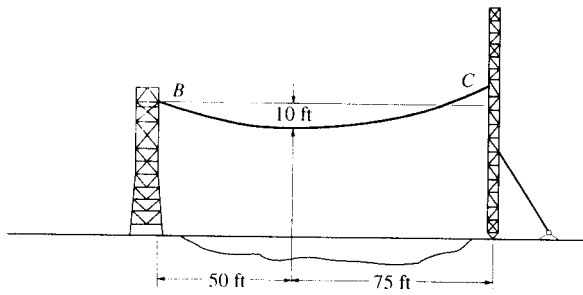

$$\bar{w} = 20 \text{ lb/ft}$$

From Example 7-15,

$$y = \frac{F_H}{w_0} \left[\cosh\left(\frac{w_0}{F_H}x\right) - 1 \right]$$

At *B* :

$$10 = \frac{F_H}{20} \left[\cosh\left(\frac{20}{F_H}(50)\right) - 1 \right]$$

Solving,

$$F_H = 2532 \text{ lb}$$

$$\frac{dy}{dx} = \sinh\left(\frac{w_0}{F_H}x\right) = \sinh\left(\frac{20(50)}{2532}\right) = 0.40529$$

$$\theta = \tan^{-1}(0.40529) = 22.06^\circ$$

$$(T_{max})_B = \frac{2532}{\cos 22.06^\circ} = 2732 \text{ lb} = 2.73 \text{ kip} \quad \text{Ans}$$

At *C* :

$$\frac{dy}{dx} = \sinh\left(\frac{w_0}{F_H}x\right) = \sinh\left(\frac{20(75)}{2532}\right) = 0.6277$$

$$\theta = \tan^{-1}(0.6277) = 32.12^\circ$$

$$(T_{max})_C = 2532/\cos 32.12^\circ = 2989 \text{ lb} = 2.99 \text{ kip} \quad \text{Ans}$$

7-110. The cable weighs 6 lb/ft and is 150 ft in length. Determine the sag h so that the cable spans 100 ft. Find the minimum tension in the cable.

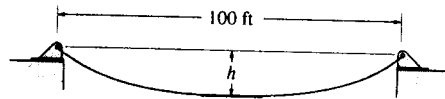

Deflection Curve of The Cable :

$$x = \int \frac{ds}{\left[1 + \left(\frac{1}{F_H}\right) (w_0 ds)^2\right]^{1/2}} \quad \text{where } w_0 = 6 \text{ lb/ft}$$

Performing the integration yields

$$x = \frac{F_H}{6} \left\{ \sinh^{-1} \left[\frac{1}{F_H} (6s + C_1) \right] + C_2 \right\} \quad [1]$$

From Eq. 7-14

$$\frac{dy}{dx} = \frac{1}{F_H} \int w_0 ds = \frac{1}{F_H} (6s + C_1) \quad [2]$$

Boundary Conditions :

$$\frac{dy}{dx} = 0 \text{ at } s = 0. \text{ From Eq. [2]} \quad 0 = \frac{1}{F_H} (0 + C_1) \quad C_1 = 0$$

Then, Eq. [2] becomes

$$\frac{dy}{dx} = \tan \theta = \frac{6s}{F_H} \quad [3]$$

$s = 0$ at $x = 0$ and use the result $C_1 = 0$. From Eq. [1]

$$x = \frac{F_H}{6} \left\{ \sinh^{-1} \left[\frac{1}{F_H} (0 + 0) \right] + C_2 \right\} \quad C_2 = 0$$

Rearranging Eq. [1], we have

$$s = \frac{F_H}{6} \sinh \left(\frac{6}{F_H} x \right) \quad [4]$$

Substituting Eq. [4] into [3] yields

$$\frac{dy}{dx} = \sinh \left(\frac{6}{F_H} x \right)$$

Performing the integration

$$y = \frac{F_H}{6} \cosh \left(\frac{6}{F_H} x \right) + C_3 \quad [5]$$

$y = 0$ at $x = 0$. From Eq. [5] $0 = \frac{F_H}{6} \cosh 0 + C_3$, thus, $C_3 = -\frac{F_H}{6}$

Then, Eq. [5] becomes

$$y = \frac{F_H}{6} \left[\cosh \left(\frac{6}{F_H} x \right) - 1 \right] \quad [6]$$

$s = 75$ ft at $x = 50$ ft. From Eq. [4]

$$75 = \frac{F_H}{6} \sinh \left[\frac{6}{F_H} (50) \right]$$

By trial and error

$$F_H = 184.9419 \text{ lb}$$

The maximum tension occurs at $\theta = \theta_{\text{min}} = 0^\circ$. Thus,

$$T_{\text{min}} = \frac{F_H}{\cos \theta_{\text{min}}} = \frac{184.9419}{\cos 0^\circ} = 185 \text{ lb}$$

Ans

$y = h$ at $x = 50$ ft. From Eq. [6]

$$h = \frac{184.9419}{6} \left\{ \cosh \left[\frac{6}{184.9419} (50) \right] - 1 \right\} = 50.3 \text{ ft} \quad \text{Ans}$$

7-111. A telephone line (cable) stretches between two points which are 150 ft apart and at the same elevation. The line sags 5 ft and the cable has a weight of 0.3 lb/ft. Determine the length of the cable and the maximum tension in the cable.

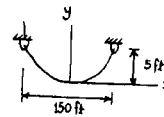
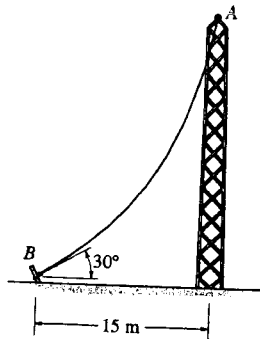

$$w = 0.3 \text{ lb/ft}$$

From Example 7-15,

$$s = \frac{F_H}{w} \sinh\left(\frac{w}{F_H} x\right)$$

$$y = \frac{F_H}{w} \left[\cosh\left(\frac{w}{F_H} x\right) - 1 \right]$$

$$\text{At } x = 75 \text{ ft, } y = 5 \text{ ft, } w = 0.3 \text{ lb/ft}$$

$$5 = \frac{F_H}{w} \left[\cosh\left(\frac{75w}{F_H}\right) - 1 \right]$$

$$F_H = 169.0 \text{ lb}$$

$$\left. \frac{dy}{dx} \right|_{\max} = \tan \theta_{\max} = \sinh\left(\frac{w}{F_H} x\right) \Big|_{x=75 \text{ ft}}$$

$$\theta_{\max} = \tan^{-1} \left[\sinh\left(\frac{75(0.3)}{169}\right) \right] = 7.606^\circ$$

$$T_{\max} = \frac{F_H}{\cos \theta_{\max}} = \frac{169}{\cos 7.606^\circ} = 170 \text{ lb} \quad \text{Ans}$$

$$s = \frac{169.0}{0.3} \sinh\left[\frac{0.3}{169.0}(75)\right] = 75.22$$

$$L = 2s = 150 \text{ ft} \quad \text{Ans}$$

7-112. The cable has a mass of 0.5 kg/m and is 25 m long. Determine the vertical and horizontal components of force it exerts on the top of the tower.

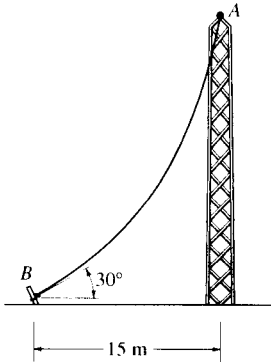

$$x = \int \frac{ds}{\left\{1 + \frac{1}{F_H^2} (w_0 ds)^2\right\}^{\frac{1}{2}}}$$

Performing the integration yields :

$$x = \frac{F_H}{4.905} \left\{ \sinh^{-1} \left[\frac{1}{F_H} (4.905s + C_1) \right] + C_2 \right\} \quad [1]$$

From Eq. 7-13

$$\frac{dy}{dx} = \frac{1}{F_H} \int w_0 ds$$

$$\frac{dy}{dx} = \frac{1}{F_H} (4.905s + C_1)$$

At $s = 0$; $\frac{dy}{dx} = \tan 30^\circ$. Hence $C_1 = F_H \tan 30^\circ$

$$\frac{dy}{dx} = \frac{4.905s}{F_H} + \tan 30^\circ \quad [2]$$

Applying boundary conditions at $x = 0$; $s = 0$ to Eq.[1] and using the result $C_1 = F_H \tan 30^\circ$ yields $C_2 = -\sinh^{-1}(\tan 30^\circ)$. Hence

$$x = \frac{F_H}{4.905} \left\{ \sinh^{-1} \left[\frac{1}{F_H} (4.905s + F_H \tan 30^\circ) \right] - \sinh^{-1}(\tan 30^\circ) \right\} \quad [3]$$

At $x = 15$ m; $s = 25$ m. From Eq.[3]

$$15 = \frac{F_H}{4.905} \left\{ \sinh^{-1} \left[\frac{1}{F_H} (4.905(25) + F_H \tan 30^\circ) \right] - \sinh^{-1}(\tan 30^\circ) \right\}$$

By trial and error $F_H = 73.94$ N

At point A, $s = 25$ m From Eq.[2]

$$\tan \theta_A = \left. \frac{dy}{dx} \right|_{s=25} = \frac{4.905(25)}{73.94} + \tan 30^\circ \quad \theta_A = 65.90^\circ$$

$$(F_v)_A = F_H \tan \theta_A = 73.94 \tan 65.90^\circ = 165 \text{ N} \quad \text{Ans}$$

$$(F_H)_A = F_H = 73.9 \text{ N} \quad \text{Ans}$$

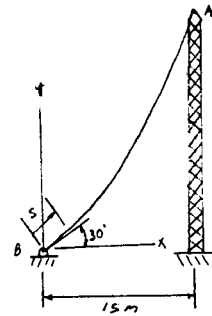

Prob. 7-113. A 50-ft cable is suspended between two points a distance of 15 ft apart and at the same elevation. If the minimum tension in the cable is 200 lb, determine the total weight of the cable and the maximum tension developed in the cable.

$$T_{\min} = F_H = 200 \text{ lb}$$

From Example 7-15 :

$$s = \frac{F_H}{w_0} \sinh \left(\frac{w_0 x}{F_H} \right)$$

$$\frac{50}{2} = \frac{200}{w_0} \sinh \left(\frac{w_0}{200} \left(\frac{15}{2} \right) \right)$$

Solving,

$$w_0 = 79.9 \text{ lb/ft}$$

$$\text{Total weight} = w_0 l = 79.9 (50) = 4.00 \text{ kip} \quad \text{Ans}$$

$$\left. \frac{dy}{dx} \right|_{x=s} = \tan \theta_{\max} = \frac{w_0 s}{F_H}$$

$$\theta_{\max} = \tan^{-1} \left[\frac{79.9 (25)}{200} \right] = 84.3^\circ$$

Then,

$$T_{\max} = \frac{F_H}{\cos \theta_{\max}} = \frac{200}{\cos 84.3^\circ} = 2.01 \text{ kip} \quad \text{Ans}$$

7-114. The man picks up the 52-ft chain and holds it just high enough so it is completely off the ground. The chain has points of attachment A and B that are 50 ft apart. If the chain has a weight of 3 lb/ft, and the man weighs 150 lb, determine the force he exerts on the ground. Also, how high h must he lift the chain? *Hint:* The slopes at A and B are zero.

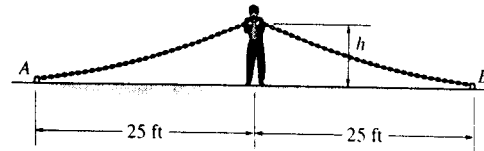

Deflection Curve of The Cable :

$$x = \int \frac{ds}{\left[1 + \left(\frac{1}{F_H^2}\right) \left(\int w_0 ds\right)^2\right]^{3/2}} \quad \text{where } w_0 = 3 \text{ lb/ft}$$

Performing the integration yields

$$x = \frac{F_H}{3} \left\{ \sinh^{-1} \left[\frac{1}{F_H} (3s + C_1) \right] + C_2 \right\} \quad [1]$$

From Eq. 7-14

$$\frac{dy}{dx} = \frac{1}{F_H} \int w_0 ds = \frac{1}{F_H} (3s + C_1) \quad [2]$$

Boundary Conditions :

$$\frac{dy}{dx} = 0 \text{ at } s = 0. \text{ From Eq. [2]} \quad 0 = \frac{1}{F_H} (0 + C_1) \quad C_1 = 0$$

Then, Eq. [2] becomes

$$\frac{dy}{dx} = \tan \theta = \frac{3s}{F_H} \quad [3]$$

$s = 0$ at $x = 0$ and use the result $C_1 = 0$. From Eq. [1]

$$x = \frac{F_H}{3} \left\{ \sinh^{-1} \left[\frac{1}{F_H} (0 + 0) \right] + C_2 \right\} \quad C_2 = 0$$

Rearranging Eq. [1], we have

$$s = \frac{F_H}{3} \sinh \left(\frac{3}{F_H} x \right) \quad [4]$$

Substituting Eq. [4] into [3] yields

$$\frac{dy}{dx} = \sinh \left(\frac{3}{F_H} x \right)$$

Performing the integration

$$y = \frac{F_H}{3} \cosh \left(\frac{3}{F_H} x \right) + C_3 \quad [5]$$

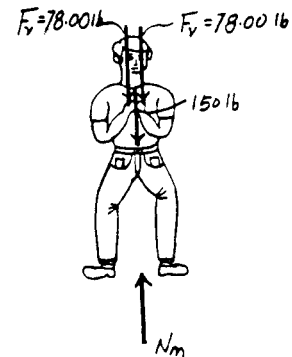
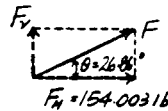

$$y = 0 \text{ at } x = 0. \text{ From Eq. [5]} \quad 0 = \frac{F_H}{3} \cosh 0 + C_3, \text{ thus, } C_3 = -\frac{F_H}{3}$$

Then, Eq. [5] becomes

$$y = \frac{F_H}{3} \left[\cosh \left(\frac{3}{F_H} x \right) - 1 \right] \quad [6]$$

$s = 26$ ft at $x = 25$ ft. From Eq. [4]

$$26 = \frac{F_H}{3} \sinh \left[\frac{3}{F_H} (25) \right]$$

By trial and error

$$F_H = 154.003 \text{ lb}$$

$y = h$ at $x = 25$ ft. From Eq. [6]

$$h = \frac{154.003}{3} \left\{ \cosh \left[\frac{3}{154.003} (25) \right] - 1 \right\} = 6.21 \text{ ft} \quad \text{Ans}$$

From Eq. [3]

$$\left. \frac{dy}{dx} \right|_{x=26 \text{ ft}} = \tan \theta = \frac{3(26)}{154.003} = 0.5065 \quad \theta = 26.86^\circ$$

The vertical force F_V that each chain exerts on the man is

$$F_V = F_H \tan \theta = 154.003 \tan 26.86^\circ = 78.00 \text{ lb}$$

Equation of Equilibrium : By considering the equilibrium of the man,

$$+\uparrow \Sigma F_y = 0; \quad N_m - 150 - 2(78.00) = 0 \quad N_m = 306 \text{ lb} \quad \text{Ans}$$

7-115. The balloon is held in place using a 400-ft cord that weighs 0.8 lb/ft and makes a 60° angle with the horizontal. If the tension in the cord at point A is 150 lb, determine the length of the cord, l , that is lying on the ground and the height h . *Hint:* Establish the coordinate system at B as shown.

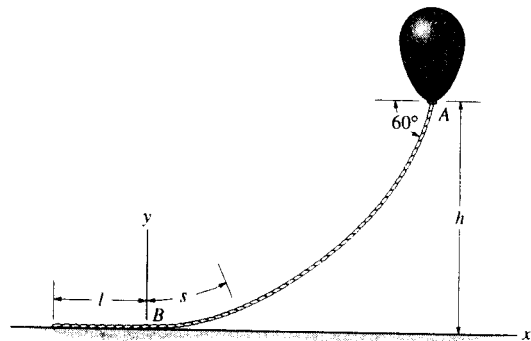

Deflection Curve of The Cable :

$$x = \int \frac{ds}{\left[1 + \left(\frac{1}{F_H^2}\right) \left(\int w_0 ds\right)^2\right]^{3/2}} \quad \text{where } w_0 = 0.8 \text{ lb/ft}$$

Performing the integration yields

$$x = \frac{F_H}{0.8} \left\{ \sinh^{-1} \left[\frac{1}{F_H} (0.8s + C_1) \right] + C_2 \right\} \quad [1]$$

From Eq. 7-14

$$\frac{dy}{dx} = \frac{1}{F_H} \int w_0 ds = \frac{1}{F_H} (0.8s + C_1) \quad [2]$$

Boundary Conditions :

$$\frac{dy}{dx} = 0 \text{ at } s = 0. \text{ From Eq. [2]} \quad 0 = \frac{1}{F_H} (0 + C_1) \quad C_1 = 0$$

Then, Eq. [2] becomes

$$\frac{dy}{dx} = \tan \theta = \frac{0.8s}{F_H} \quad [3]$$

$s = 0$ at $x = 0$ and use the result $C_1 = 0$. From Eq. [1]

$$x = \frac{F_H}{3} \left\{ \sinh^{-1} \left[\frac{1}{F_H} (0 + 0) \right] + C_2 \right\} \quad C_2 = 0$$

Rearranging Eq. [1], we have

$$s = \frac{F_H}{0.8} \sinh \left(\frac{0.8}{F_H} x \right) \quad [4]$$

Substituting Eq. [4] into [3] yields

$$\frac{dy}{dx} = \sinh \left(\frac{0.8}{F_H} x \right)$$

Performing the integration

$$y = \frac{F_H}{0.8} \cosh \left(\frac{0.8}{F_H} x \right) + C_3 \quad [5]$$

$y = 0$ at $x = 0$. From Eq. [5] $0 = \frac{F_H}{0.8} \cosh 0 + C_3$, thus, $C_3 = -\frac{F_H}{0.8}$

Then, Eq. [5] becomes

$$y = \frac{F_H}{0.8} \left[\cosh \left(\frac{0.8}{F_H} x \right) - 1 \right] \quad [6]$$

The tension developed at the end of the cord is $T = 150$ lb and $\theta = 60^\circ$. Thus

$$T = \frac{F_H}{\cos \theta} \quad 150 = \frac{F_H}{\cos 60^\circ} \quad F_H = 75.0 \text{ lb}$$

From Eq. [3]

$$\frac{dy}{dx} = \tan 60^\circ = \frac{0.8s}{75} \quad s = 162.38 \text{ ft}$$

Thus,

$$l = 400 - 162.38 = 238 \text{ ft}$$

Substituting $s = 162.38$ ft into Eq. [4],

Ans

$$162.38 = \frac{75}{0.8} \sinh \left(\frac{0.8}{75} x \right) \quad x = 123.46 \text{ ft}$$

$y = h$ at $x = 123.46$ ft. From Eq. [6]

$$h = \frac{75.0}{0.8} \left[\cosh \left[\frac{0.8}{75.0} (123.46) \right] - 1 \right] = 93.75 \text{ ft} \quad \text{Ans}$$

7-11. A 100-lb cable is attached between two points at a distance 50 ft apart having equal elevations. If the maximum tension developed in the cable is 75 lb, determine the length of the cable and the sag.

From Example 7-15,

$$T_{max} = \frac{F_H}{\cos \theta_{max}} = 75 \text{ lb}$$

$$\cos \theta_{max} = \frac{F_H}{75}$$

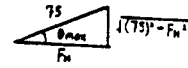

For $\frac{1}{2}$ of cable,

$$w_0 = \frac{\frac{100}{2}}{s} = \frac{50}{s}$$

$$\tan \theta_{max} = \frac{w_0 s}{F_H} = \frac{\sqrt{(75)^2 - F_H^2}}{F_H} = \frac{50}{F_H}$$

Thus,

$$\sqrt{(75)^2 - F_H^2} = 50; \quad F_H = 55.9 \text{ lb}$$

$$s = \frac{F_H}{w_0} \sinh\left(\frac{w_0 s}{F_H}\right) = \frac{55.9}{\left(\frac{50}{s}\right)} \sinh\left\{\left(\frac{50}{s(55.9)}\right)\left(\frac{50}{2}\right)\right\}$$

$$s = 27.8 \text{ ft}$$

$$w_0 = \frac{50}{27.8} = 1.80 \text{ lb/ft}$$

$$\text{Total length} = 2s = 55.6 \text{ ft} \quad \text{Ans}$$

$$h = \frac{F_H}{w_0} \left[\cosh\left(\frac{w_0 L}{2 F_H}\right) - 1 \right] = \frac{55.9}{1.80} \left[\cosh\left(\frac{1.80(50)}{2(55.9)}\right) - 1 \right]$$

$$= 10.6 \text{ ft} \quad \text{Ans}$$

7-117. Determine the distance a between the supports in terms of the beam's length L so that the moment in the symmetric beam is zero at the beam's center.

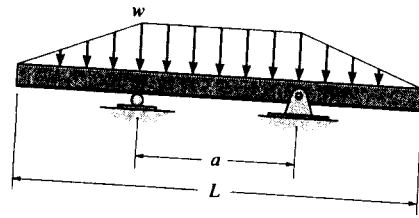

Support Reactions : From FBD (a),

$$\sum M_C = 0; \quad \frac{w}{2}(L+a)\left(\frac{a}{2}\right) - B_y(a) = 0 \quad B_y = \frac{w}{4}(L+a)$$

Free body Diagram : The FBD for segment AC sectioned through point C is drawn.

Internal Forces : This problem requires $M_C = 0$. Summing moments about point C [FBD (b)], we have

$$\begin{aligned} \sum M_C = 0; \quad & \frac{wa}{2}\left(\frac{a}{4}\right) + \frac{w}{4}(L-a)\left[\frac{1}{6}(2a+L)\right] \\ & - \frac{w}{4}(L+a)\left(\frac{a}{2}\right) = 0 \\ & 2a^2 + 2aL - L^2 = 0 \\ & a = 0.366L \end{aligned}$$

Ans

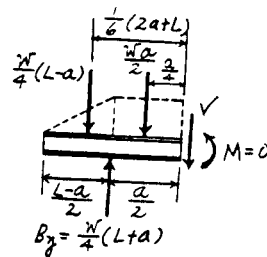
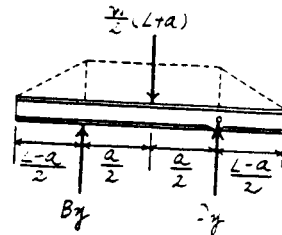

7-118. Draw the shear and moment diagrams for the beam.

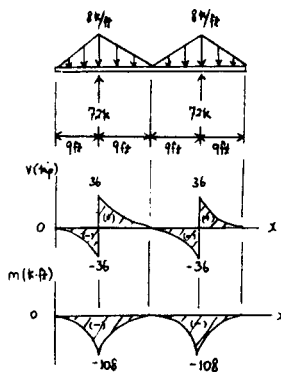
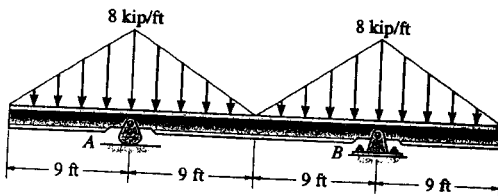

7-11. Draw the shear and moment diagrams for the beam ABC.

Support Reactions: The 6 kN load can be replaced by an equivalent force and couple moment at B as shown on FBD (a).

$$\begin{aligned} \sum M_A = 0; & \quad F_{CD} \sin 45^\circ (6) - 6(3) - 9.00 = 0 \quad F_{CD} = 6.364 \text{ kN} \\ \sum F_y = 0; & \quad A_y + 6.364 \sin 45^\circ - 6 = 0 \quad A_y = 1.50 \text{ kN} \end{aligned}$$

Shear and Moment Functions: For $0 \leq x < 3 \text{ m}$ [FBD (b)].

$$\sum F_y = 0; \quad 1.50 - V = 0 \quad V = 1.50 \text{ kN} \quad \text{Ans}$$

$$\sum M = 0; \quad M - 1.50x = 0 \quad M = (1.50x) \text{ kN} \cdot \text{m} \quad \text{Ans}$$

For $3 \text{ m} < x \leq 6 \text{ m}$ [FBD (c)].

$$\sum F_y = 0; \quad V + 6.364 \sin 45^\circ = 0 \quad V = -4.50 \text{ kN} \quad \text{Ans}$$

$$\sum M = 0; \quad 6.364 \sin 45^\circ (6-x) - M = 0 \\ M = (27.0 - 4.50x) \text{ kN} \cdot \text{m} \quad \text{Ans}$$

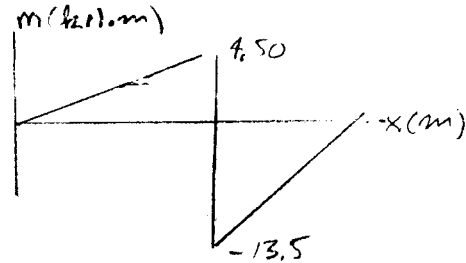
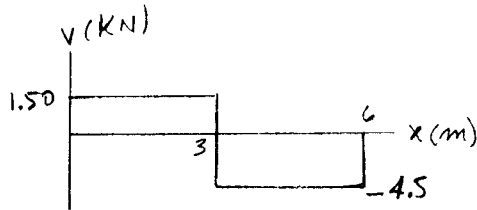
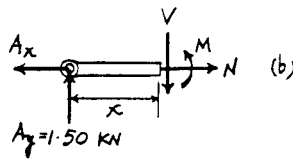
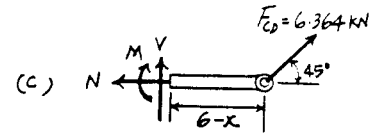
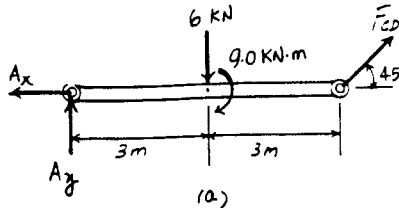
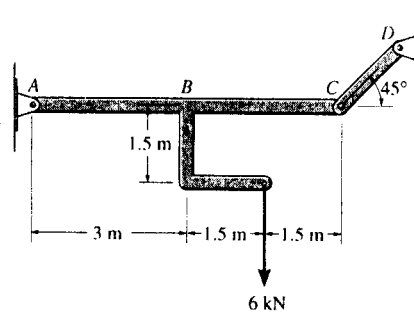

7-120. Draw the shear and moment diagrams for the beam.

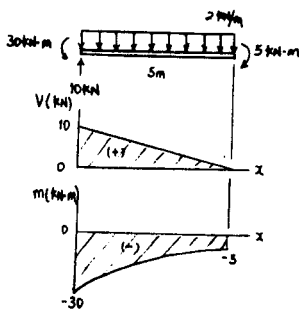
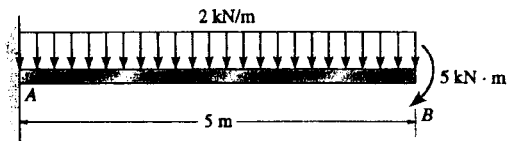

7-121. Determine the normal force, shear force, and moment at points *B* and *C* of the beam.

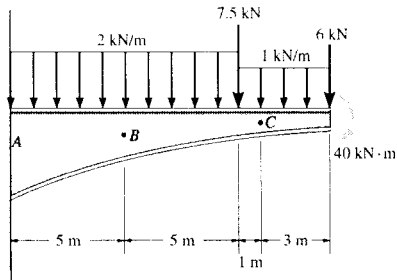

Free body Diagram: The Support reactions need not be computed for this case.

Internal Forces: Applying the equations of equilibrium to segment *DC* [FBD (a)], we have

$$\rightarrow \Sigma F_x = 0; \quad N_C = 0 \quad \text{Ans}$$

$$+ \uparrow \Sigma F_y = 0; \quad V_C - 3.00 - 6 = 0 \quad V_C = 9.00 \text{ kN} \quad \text{Ans}$$

$$\curvearrowleft + \Sigma M_C = 0; \quad -M_C - 3.00(1.5) - 6(3) - 40 = 0$$

$$M_C = -62.5 \text{ kN}\cdot\text{m} \quad \text{Ans}$$

Applying the equations of equilibrium to segment *DB* [FBD (b)], we have

$$\rightarrow \Sigma F_x = 0; \quad N_B = 0 \quad \text{Ans}$$

$$+ \uparrow \Sigma F_y = 0; \quad V_B - 10.0 - 7.5 - 4.00 - 6 = 0$$

$$V_B = 27.5 \text{ kN} \quad \text{Ans}$$

$$\curvearrowleft + \Sigma M_B = 0; \quad -M_B - 10.0(2.5) - 7.5(5)$$

$$- 4.00(7) - 6(9) - 40 = 0$$

$$M_B = -184.5 \text{ kN}\cdot\text{m} \quad \text{Ans}$$

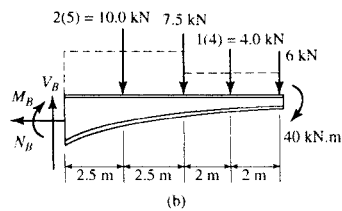
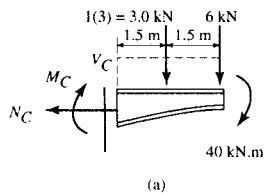

7-122. A chain is suspended between points at the same elevation and spaced a distance of 60 ft apart. If it has a weight of 0.5 lb/ft and the sag is 3 ft, determine the maximum tension in the chain.

$$x = \int \frac{ds}{\left\{1 + \frac{1}{F_H^2} (w_0 ds)^2\right\}^{1/2}}$$

Performing the integration yields :

$$x = \frac{F_H}{0.5} \left\{ \sinh^{-1} \left[\frac{1}{F_H} (0.5s + C_1) \right] + C_2 \right\} \quad [1]$$

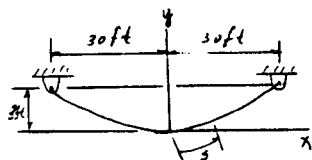

From Eq. 7-13

$$\frac{dy}{dx} = \frac{1}{F_H} \int w_0 ds$$

$$\frac{dy}{dx} = \frac{1}{F_H} (0.5s + C_1)$$

At $s = 0$; $\frac{dy}{dx} = 0$ hence $C_1 = 0$

$$\frac{dy}{dx} = \tan \theta = \frac{0.5s}{F_H} \quad [2]$$

Applying boundary conditions at $x = 0$; $s = 0$ to Eq.[1] and using the result $C_1 = 0$ yields $C_2 = 0$. Hence

$$s = \frac{F_H}{0.5} \sinh \left(\frac{0.5}{F_H} x \right) \quad [3]$$

Substituting Eq.[3] into [2] yields :

$$\frac{dy}{dx} = \sinh \left(\frac{0.5x}{F_H} \right) \quad [4]$$

Performing the integration

$$y = \frac{F_H}{0.5} \cosh \left(\frac{0.5}{F_H} x \right) + C_3$$

Applying boundary conditions at $x = 0$; $y = 0$ yields $C_3 = -\frac{F_H}{0.5}$. Therefore

$$y = \frac{F_H}{0.5} \left[\cosh \left(\frac{0.5}{F_H} x \right) - 1 \right]$$

At $x = 30$ ft; $y = 3$ ft $3 = \frac{F_H}{0.5} \left[\cosh \left(\frac{0.5}{F_H} (30) \right) - 1 \right]$

By trial and error $F_H = 75.25$ lb

At $x = 30$ ft; $\theta = \theta_{max}$. From Eq.[4]

$$\tan \theta_{max} = \frac{dy}{dx} \Big|_{x=30 \text{ ft}} = \sinh \left(\frac{0.5(30)}{75.25} \right) \quad \theta_{max} = 11.346^\circ$$

$$T_{max} = \frac{F_H}{\cos \theta_{max}} = \frac{75.25}{\cos 11.346^\circ} = 76.7 \text{ lb.} \quad \text{Ans}$$

7-123. Draw the shear and moment diagrams for the beam.

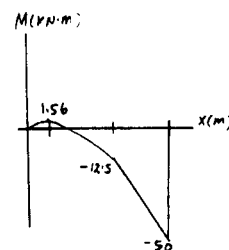
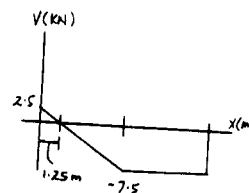
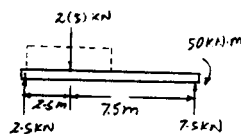
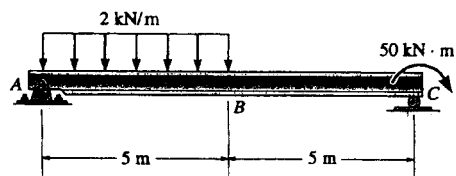

8-1. The mine car and its contents have a total mass of 6 Mg and a center of gravity at G . If the coefficient of static friction between the wheels and the tracks is $\mu_s = 0.4$ when the wheels are locked, find the normal force acting on the front wheels at B and the rear wheels at A when (a) only the brakes at A are locked, and (b) the brakes at both A and B are locked. In either case, does the car move?

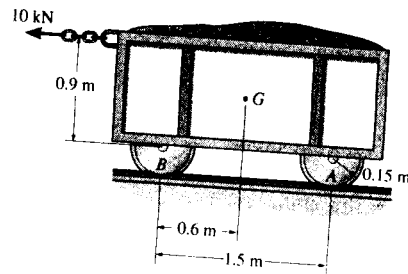

Equations of Equilibrium: The normal reactions acting on the wheels at (A and B) are independent as to whether the wheels are locked or not. Hence, The normal reactions acting on the wheels are the same for both cases.

$$\begin{aligned} \sum M_B = 0; \quad N_A(1.5) + 10(1.05) - 58.86(0.6) &= 0 \\ N_A &= 16.544 \text{ kN} = 16.5 \text{ kN} \quad \text{Ans} \end{aligned}$$

$$\begin{aligned} \sum F_y = 0; \quad N_B + 16.544 - 58.86 &= 0 \\ N_B &= 42.316 \text{ kN} = 42.3 \text{ kN} \quad \text{Ans} \end{aligned}$$

Friction: When the wheels at A are locked, $(F_A)_{\max} = \mu_s N_A = 0.4(16.544) = 6.6176 \text{ kN}$. Since $(F_A)_{\max} < 10 \text{ kN}$, the wheels at A will slip and the wheels at B will roll. Thus, **the mine car moves.**

When both wheels at A and B are locked, then $(F_A)_{\max} = \mu_s N_A = 0.4(16.544) = 6.6176 \text{ kN}$ and $(F_B)_{\max} = \mu_s N_B = 0.4(42.316) = 16.9264 \text{ kN}$. Since $(F_A)_{\max} + (F_B)_{\max} = 23.544 \text{ kN} > 10 \text{ kN}$, the wheels do not slip. Thus, **the mine car does not move.**

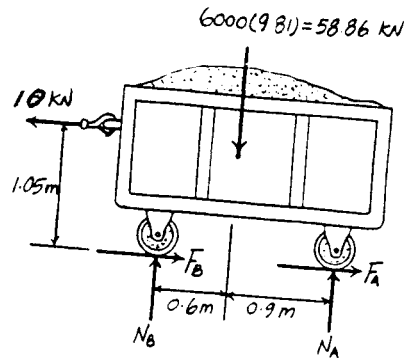

8-2. If the horizontal force $P = 80 \text{ lb}$, determine the normal and frictional forces acting on the 300-lb crate. Take $\mu_s = 0.3$, $\mu_k = 0.2$.

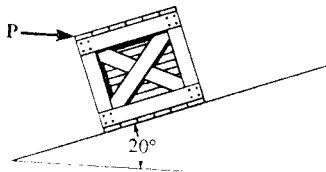

Assume no slipping:

$$\sum F_x = 0; \quad 80 \cos 20^\circ - 300 \sin 20^\circ + F_c = 0$$

$$F_c = 27.43 \text{ lb}$$

$$\sum F_y = 0; \quad N_c - 300 \cos 20^\circ - 80 \sin 20^\circ = 0$$

$$N_c = 309.26 \text{ lb}$$

$$(F_c)_{\max} = \mu_s N_c; \quad (F_c)_{\max} = 0.3(309.26) = 92.8 \text{ lb} > 27.43 \text{ lb} \quad (\text{O.K.})$$

$$F_c = 27.4 \text{ lb} \quad \text{Ans}$$

$$N_c = 309 \text{ lb} \quad \text{Ans}$$

